

# TRANSPAC 52 RULE

## (TP52 RULE)

# 2026

CHANGES FROM 2025 IN **RED**

Approved by 2025 TP52 Annual Class Meeting and World Sailing



<b>INDEX</b>	<b>2</b>
<b>INTRODUCTION.</b>	<b>3</b>
<b>PART I – ADMINISTRATION.</b>	<b>4</b>
<b>SECTION A – GENERAL.</b>	<b>4 - 7</b>
<b>SECTION B - BOAT ELIGIBILITY.</b>	<b>8</b>
<b>PART II – REQUIREMENTS AND LIMITATIONS.</b>	<b>9</b>
<b>SECTION C - CONDITIONS FOR RACING.</b>	<b>9 - 14</b>
<b>SECTION D - LIMITATIONS (The BOX).</b>	<b>15 - 20</b>
<b>SECTION E - HULL.</b>	<b>21 - 26</b>
<b>SECTION F - HULL APPENDAGES.</b>	<b>27 - 30</b>
<b>SECTION G - INTERIOR, ENGINE AND PROPELLOR.</b>	<b>31 - 34</b>
<b>SECTION H - EQUIPMENT.</b>	<b>35 - 36</b>
<b>SECTION I - RIG.</b>	<b>37 - 41</b>
<b>SECTION J - SAILS.</b>	<b>42 - 45</b>
<b>SECTION K - MEASUREMENTS.</b>	<b>46 - 49</b>
<b>SECTION L - OWNER'S RESPONSIBILITIES.</b>	<b>50 - 52</b>
<b>INDEX OF SYMBOLS</b>	<b>53</b>
<b>PART III APPENDICES</b>	<b>54</b>
<b>APPENDIX 1</b>	<b>54 - 55</b>
<b>APPENDIX 2a</b>	<b>56</b>
<b>APPENDIX 2b</b>	<b>57</b>
<b>APPENDIX 3</b>	<b>58</b>
<b>APPENDIX 4</b>	<b>59 - 60</b>
<b>APPENDIX 5</b>	<b>61 - 62</b>

**INTRODUCTION.**

*The Transpac 52 Rule (TP52 Rule) is intended to produce a class of fast, monohull keelboats for high quality level racing. Development is allowed in such factors as hull shape, foil shape, construction, interior, deck layout and rigging.*

*However, speed producing factors such as length, displacement, draft and sail area are strictly controlled. Boats in this Class shall sail without time allowance. Any developments which are contrary to this purpose may give rise to rule changes.*

*Acknowledging that it is difficult to cover every condition and innovation, designers, builders, owners and crew carry the responsibility for complying with the intent and spirit of the TP52 Rule.*

*The TP52 Class therefore reserves the right to refuse or to award a TP52 Certificate as it considers appropriate and to interpret clauses of the TP52 Rule at any time. The substance of any design feature or innovations presented for measurement or interpretation shall be made available to any person on request.*

*These are **Closed Class Rules**. Anything that is not expressly permitted by the TP52 Rule is prohibited.*

**NOTE:**

*In case of changes other than repairs to the hull, deck and structure of boats build under the pre **2026** rules these changes shall comply with the requirements as set in E.2 of this rule.*

*This Class Rule will go to WS for approval. WS might require changes. These will be communicated and if required brought up for approval by the Members.*

**PART I – ADMINISTRATION.****SECTION A – GENERAL.****A.1 LANGUAGE.**

A.1.1 The official language of the class is English and in case of dispute over translation the English text shall prevail.

A.1.2 The word “shall” is mandatory and the words “may” and “can” are permissive.

**A.2 ABBREVIATIONS.**

A.2.1 WS World Sailing Federation  
MNA WS Member National Authority  
ICA International Class Association  
RCA Regional Class Association  
ERS Equipment Rules of Sailing  
RRS Racing Rules of Sailing  
OSR Offshore Special Regulations

**A.3 AUTHORITIES.**

A.3.1 The international authority of the class is WS which shall co-operate with the TP52 Class (ICA) in all matters concerning these **class rules**.

**A.4 ADMINISTRATION OF THE CLASS.**

A.4.1 WS has delegated its administrative functions of the class to the TP52 Class (ICA).

A.4.2 The ICA may delegate a part of the administration to a RCA.

**A.5 WS RULES.**

A.5.1 The TP52 Rule shall be read in conjunction with the ERS.

A.5.2 Except where used in headings, when a term is printed in “**bold**” the definition in the ERS applies and when a term is printed in “*italics*” the definition in the RRS applies.

**A.6 CLASS RULES VARIATIONS.**

A.6.1 At Class Events WS Regulation 10.5(f) applies. At all other events RRS 87 applies.

**A.7 CLASS RULES AMENDMENTS.**

A.7.1 Amendments to the TP52 Rule shall be proposed by the TP52 Class (ICA) and are subject to the approval of WS in accordance with the WS - TP52 Class - Agreement.

**A.8 CLASS RULES INTERPRETATION.**

A.8.1 Interpretation of the TP52 Rule shall be made in accordance with the WS -TP52 Class - Agreement and the TP52 Bylaws.

**A.9 INTERNATIONAL CLASS FEE AND WS BUILDING PLAQUE.**

A.9.1 The TP52 Class shall pay the International Class Fee.

A.9.2 WS shall, after having received the International Class Fee, send the WS Building Plaque to the TP52 Class.

**A.10 SAIL NUMBERS.**

A.10.1 Sail numbers shall be issued by a boat’s MNA.

**A.11 CERTIFICATION.**

- A.11.1 A **certificate** shall be issued by the TP52 Chief Measurer and shall, besides the measured information, record the following information:
- (a) Sailnumber
  - (b) Owner / Class Member
  - (c) **Hull** identification / Name of **boat**
  - (d) Date of issue initial **certificate**
  - (e) Date of issue of **certificate**
  - (f) Designer details
  - (g) Builder details
  - (h) Measurer(s) name(s)
- A.11.2 To be valid a TP52 **Certificate** must bear the names and signatures of the TP52 Class Manager and TP52 Chief Measurer. No **boat** shall have more than one valid TP52 **Certificate** at any time. A copy of the TP52 **Certificate** shall always be on board the **boat**.
- A.11.3 The maximum number of TP52 **Certificates** supplied within any calendar year as result of changes to the **boat** that require remeasurement shall be two **after having received its first certificate of the year (so, max three in total per year)**. A **bulb**, or **fin**, or bulb/fin combination change **or a bulb or fin modification requiring remeasurement** shall only be accommodated once after the first race under the first certificate issued for a calendar year within any calendar year. These numbers may be increased by the TP52 Chief Measurer in case of unforeseen revisions, for instance as the result of a repair.
- A.11.4 TP52 **Certificates** shall be of the form as shown in Appendix 1 and shall be supplied to any TP52 Class Member on request. A levy for such service may be determined by the TP52 Class.
- A.11.5 TP52 **Certificates** shall not be issued *during* the 7 days before the start of a race or the first race of an event. The TP52 Chief Measurer may decide to issue within that period, but such a **certificate** may be withdrawn without the option of appeal as mentioned in Appendix 6.3.
- A.11.6 The TP52 Class reserves the right to refuse, withdraw or award a TP52 **Certificate** as it considers appropriate. This decision shall not be grounds for any claim whatsoever.
- A.12 INITIAL HULL CERTIFICATION.**
- A.12.1 For a **boat** not previously **certified** a TP52 Measurer shall measure / identify all required details and enter these onto the **certification** input form.
- A.12.2 The **certification** input form and the **certification** fee (if required) shall be sent to the TP52 Chief Measurer.
- A.12.3 Upon receipt of a satisfactorily completed documentation and the **certification** fee, the TP52 Chief Measurer may issue a **certificate**.

**A.13 VALIDITY OF CERTIFICATE.**

- A.13.1 A TP52 **Certificate** becomes invalid upon:
- (a) The date of expiry, which is the 1st day of each year.
  - (b) Change of ownership / loss of class membership.
  - (c) Other than permitted maintenance, alterations or repairs.
  - (d) Any alteration that brings the **boat** outside the Class Requirements/Rule.
  - (e) Withdrawal by the TP52 Chief Measurer
  - (f) The issue of a new **certificate**.

NOTE: In case of withdrawal (e) the TP52 Chief Measurer shall inform the Owner or his representative in writing of the reasons. As well as inform the race committee if at the time of the withdrawal the **boat** is under jurisdiction of a race committee.

- A.13.2 A TP52 Measurer shall report to the TP52 Class Manager or the TP52 Chief Measurer anything which he considers to be unusual or against the general interest of the TP52 Rule.

NOTE: A TP52 **Certificate** may be withhold pending examination of the case to the discretion of the TP52 Chief Measurer.

**A.14 RE - CERTIFICATION.**

- A.14.1 Upon expiry the Member shall apply to the TP52 Chief Measurer for a new **certificate** together with any re-**certification** fee that may be required. A new **certificate** shall be issued to the class member once the TP52 Chief Measurer is satisfied that no change has been made to the **boat** in any of the rule parameters.
- A.14.2 Upon change of ownership the new owner shall apply to the TP52 Chief Measurer for a new certificate together with any re-**certification** fee that may be required. A new **certificate** shall then be issued to the new owner once the TP52 Chief Measurer is satisfied that no change has been made to the **boat** in any of the rule parameters.
- A.14.3 Upon other changes to the **boat** than permitted maintenance, alterations or repairs, the relevant change(s) shall be checked by a TP52 Measurer and the details and any re-**certification** fee that may be required shall be sent to the TP52 Chief Measurer. A new **certificate**, showing the dates of initial and new **certification** control, may then be issued to the owner / class member.

**A.15 GRANDFATHERING.**

- A.15.1 Teams can request the TP52 Chief Measurer for **Boats** build to the TP52 Rule before 1 November 2012 and holding at any time a TP52 **Certificate**, and still within the limits of the TP52 Rule as in force before 1 November 2012, to be grandfathered on aspects that are or might be seen different from the TP52 Rule at that time and the 2026 TP52 Rule. The decision on this rests solely with the TP52 Chief Measurer, with the option to ask a review on this decision from the TP52 Excom.

**A.16 AGE ALLOWANCE**

- A.16.1 The Class Manager, following advise by the Technical Committee, may grant **boats** build to the 2014 or earlier versions of the TP52 Rule Age Allowance and allow adjustments by the following means:
- 1) Change DSPM in increments of 50kg.
  - 2) Change Maximum **Bulb** Weight in increments of 50kg.
  - 3) Change of **Draft** (- 0.10m)

- 4) Change in maximum **sail** area.
- 5) A combination of 1) and/or 2) and/or 3) and/or 4).

We recognize the experimental element of this arrangement, if put in place.  
Further evaluation might result in retrimming of the allowances.

**A.17 RETENTION OF CERTIFICATION DOCUMENTATION.**

- A.17.1 TP52 Measurers shall retain the original documentation upon which the current **certificate** is based.

**SECTION B - BOAT ELIGIBILITY.****B.1 CLASS RULES AND CERTIFICATION.**

- B.1.1 No **boat** shall be considered a Transpac 52 (TP52) or be eligible to race in a Transpac 52 race unless:
- a) It is in compliance with the TP52 Rule, the TP52 Bylaws and the TP52 Interpretations and has a valid TP52 **Certificate** on board when *racing*.
  - b) It is owned by a Regular Member of the TP52 Class.
  - c) It is measured by a TP52 Measurer and has a valid TP52 **Certificate** on file in the TP52 Chief Measurers office.
- B.1.2 However it will be possible under this Rule to supply a TP52, owned or chartered by a person other than a TP52 Class Member, a “One Event – TP52 **Certificate**”, on condition that:
- a) The event is approved by the TP52 ExCom as suitable for a “One Event – **Certificate**”.
  - b) The **certificate** is valid only for the duration of the Event.
  - c) The TP52 is in compliance with the TP52 Rule, the TP52 Bylaws and the TP52 Interpretations and supplies the TP52 Chief Measurer with any information required by him to substantiate this.
  - d) EUR 250.- is received with the application for the certificate.
- B.1.3 Wild Card Invitations for TP52 races / events may be extended to 52ft boats not fully compliant with the TP52 Rule if:
- 1) The event’s NOR indicates this option
  - 2) The following conditions are part of that event’s NOR:
    - Valid Measurement Certificate required. Rating limit to be given in NOR that is based on the maximum rating limit for a TP52 under the measurement system of choice. Options measurement system: IRC and ORCi.
    - LOA Max: 15.85 m
    - Beam Max: 4.42 m
    - Draft Max: 3.50 m (Boats dating from 2014 or before max 3.60m)
    - Empty DSPL Minimum: 6950kg
    - Associate Class Membership Fee paid.
    - Applicant uses the IRC52 Wild Card Application Form, see ONB on [transpac52.org](http://transpac52.org)

NOTE: Wild Card restrictions may be adjusted for individual boats outside the limits given above, reflecting the wish of the TP52 Class to include rather than to exclude boats. This decision is entirely with the TP52 Class and not open to protest, appeal or claim.

**PART II – REQUIREMENTS AND LIMITATIONS.**

The **crew** and the **boat** shall comply with the rules in Part II when *racing*. In case of conflict Section C shall prevail. The rules in Part II are **closed class rules**. **Certification control** and **equipment inspection** shall be carried out in accordance with the ERS except where varied in this Part.

**SECTION C - CONDITIONS FOR RACING.****C.1 GENERAL.**

## C.1.1 Rules (current version):

- (a) ERS Equipment Rules of Sailing
- (b) RRS Racing Rules of Sailing
- (c) OSR Offshore Special Regulations
- (d) TPB TP52 Bylaws
- (e) TPI TP52 Interpretations

## C.1.2 Alterations of the Rules of C.1.1:

- 1) Concerning RRS 42 a NoR may state that either C.1.2.A) or C.1.2.B) applies.
  - C.1.2.A):
    - i) The race committee may signal that pumping is permitted when after the starting signal a **boat** is sailing a course where the spinnaker could be hoisted and filled (change of RRS 42.2.a). The signals will be made according to RRS P5.
    - ii) The race committee shall state in the sailing instructions the minimum wind speed limit to implement Rule C.1.2.A.i. The TP52 Class recommends either no limit or a limit between 10 and 13 knots.
  - C.1.2.B):
    - 1) RRS 42 is deleted and replaced with:
      - 42 Propulsion
      - 42.1 Except when permitted in rule 42.2 or 45, a boat shall compete by using only the wind and water to increase, maintain or decrease her speed. Her crew may pump or adjust the trim of sails and hull, and perform other acts of seamanship.
      - 42.2 Any means of propulsion may be used to help a person or another vessel in danger.
- 2) In alteration to OSR 4.06 for class events a TP52 may carry only one anchor, rope and chain combination of a minimum weight of 25kg.
- 3) In alteration to OSR 3.29.6.d for class events a TP52 shall have as minimum requirement a LMR 240 co-axial feeder cable to the VHF masthead antenna. NOTE: A TP52 shall have permanently installed VHF in adequate working order at the equipment minimum specification of the rules in place, well positioned for its primary purpose and use.
- 4) TP52 Rule L.1.19 can be seen as an alteration of RRS52. If so L.1.19 shall prevail.
- 5) OSR 2.04.1 (general requirements) for class events shall not be interpreted other than that navigation lights on a TP52 shall be permanently installed.
- 6) In alteration to OSR 3.14.1.e) if a boat's first launch date is after 31 December 2024 the *inside* of pulpit and stanchion base tubes shall be no further inboard from the perimeter of the deck than 5% of boat beam or 150 mm (6"), whichever is greater, nor further out- board than the perimeter of the deck, where the perimeter of the deck is defined as the hull and deck intersection at an angle of not more than 15 degrees to the horizontal in a transverse plane when the yacht is upright. *The outside of pulpit and stanchion base tubes shall be within the 45° tangent to the sheer.*

**C.2 CREW AND HELMSMAN.**

C.2.1 Limitations: See TP52 Bylaws 5.1 and 5.2.

NOTE: Events or Regional Fleets may alter the crew weight limit, or put in place limits on driver (like owner/driver or non-pro driver) and crew (like non-pro crew), but only if this is approved in writing by the TP52 Class.

C.2.2 Weight:

NOTE: It is widely recognized that **crew** weight has an effect on boat speed. It is the Owner's responsibility to encourage a healthy crew weight plan.

- (a) The **crew** weight maximum shall be 1130.0 kilo wearing a minimum of sailing shorts and T- Shirt as used by the **crew** when *racing*. A calibrated scale shall be used. The scale shall be provided by the race organizer or the Transpac 52 Class.  
The **crew** weight shall be recorded to one decimal place of kg. Events in their NOR or SI may replace the 1130.0 kilo requirement by 1050 kilo plus a guest, or by 1220.0 kg / 1140.0kg plus a guest.
- (b) The Owner/Regular Member may select a default weight of 90.0 kilos for their weight, or 75.0 kilos in case of owner driver if so mentioned in the event's NOR. If an entire **crew** is required to weigh more than once during an event, then the Owner/ Regular Member is not required to reweigh and the first weight recorded shall be used.
- (c) At least 48 hours before the scheduled start of a Transpac 52 event, each **boat** shall file a written **crew** declaration with all **crew** member names including alternates. It shall be filed with the Class Official. A Jury approved change to the declaration shall be communicated with the Class Official. Alternatively, a Class Official may approve crew changes if so indicated in the NOR.
- (d) A **boat** shall sail with the same **crew** for the entire regatta. Any changes to the **crew** shall have proper reason, submitted in good faith to the Jury for their approval.
- (e) Within the restrictions of (c) and (d) a **boat** may change **crew** members with alternate **crew** members, as long as the correct paper work is on file with the Class Official.
- (f) Unless a different method is specified in the NOR and/or Sailing Instructions **crew** weight checks can be executed to the discretion of the TP52 Class Official/TP52 Measurer as noted in A.
- (g) Penalties shall be applied in accordance with B below.
- (h) The TP52 Class Official/TP52 Measurer shall report to the Race Committee in case he finds the **crew** weight to be over 1130.0 (1050.0) kg or the 1220.0 / 1140.0 kg option. The Race Committee shall file a protest.

- A.1 One or more **boat's** entire **crew** may be weighed after the last *race* of the day.
- A.2 The **boat(s)** shall be notified within 10 minutes of finishing any of the races for that day.
- A.3 The **crew** is allowed one trial weighing and one official weighing.
- A.4 Between the two shall be no more than 15 minutes for the complete **crew** to be weighed.
- A.5 The weighing of the entire **crew** shall be completed within 1 hour of their **boat's** finish of the last *race* of that day plus the time it takes to reach the dock from the finish at an average speed of 7 knots.
- A.6 The measurer in charge of the weight check may extend the timespan but it shall never extend beyond the protest time limit.

- B.1 Any recorded excess of the **crew** weight value of 1130.0 (1050.0) kg or the 1220.0 / 1140.0 kg option is not allowed under this rule.
- B.2 When a **crew** weight is found to be over 1130.0 (1050.0) kg and at or 1135.0 (1055.0) kg, it shall lose three places for each *race* of that day.
- B.3 When a **crew** weight is found to be over 1135.0 (1055.0) kg and at or below 1140.0 (1060.0) kg, it shall lose six places for each *race* of that day.
- B.4 When a **crew** weight is found to be over 1140.0 (1060.0) kg, it shall be scored DNS for each *race* of that day.
- B.5 During an event, if a **boat's crew** weight is found to be over 1130.0 (1050.0) kg, the **crew** shall be reweighed each remaindering day of the event.

### C.3 PERSONAL EQUIPMENT.

- C.3.1 Personal equipment shall be to the minimum standard of WS Offshore Special Regulations Category 4. (weight and position to be registered on TP52 Certificate).

### C.4 ADVERTISING.

- C.4.1 Advertising shall only be displayed in accordance with Category C of the WS Advertising Code (See WS Regulation 20).

### C.5 PORTABLE EQUIPMENT.

- C.5.1 The **boat** shall be equipped to the minimum standard WS Offshore Special Regulations Category 4 as well as comply with the following Offshore Special Regulations:
  - 3.17.1 Toe rail (grandfathered for boats built before 1-1-2025 if further inboard than ruled)
  - 3.23.1.c One permanently installed manual bilge pump operable with all hatches shut.
  - 3.28.1.b Minimum speed under engine. See D.34.
  - 3.28.1.f Fuel systems requirements.
  - 3.28.4 Battery systems requirements.
  - 3.29.6 VHF requirements (also see C.1.2.3).
  - 4.05.2 Two fire extinguishers of minimum content weight 2kg each.
  - 4.15 Emergency steering.
- C.5.2 All safety equipment carried by the **boat** shall be off the shelf / production articles (so no custom(ized) items).
- C.5.3 In variation on OSR Category 4 requirements a TP52 shall carry at least a one anchor, chain and rope combination, which shall have a minimum weight of 25kg. NOTE: The weight is given solely to avoid grossly underweight combinations to improve performance of the **boats**. It is up to the owner of a **boat** to choose the right equipment for his/her **boat**.
- C.5.4 All **boats** shall only have a provision to carry canister liferafts on deck, as close as practical (considering **crew** movements and deck layout) to the stern of the **boat**.
- C.5.5 Optional
  - (a) FOR USE:
    - (1) Electronic or mechanical timing devices
    - (2) Binoculars, handbearing compass, navigational and communication equipment including computers if not forbidden or restricted for use or function elsewhere in this rule or an event's NoR/SI.
    - (3) Toolkit (weight and position to be registered on TP52 Certificate)

- (4) Spares (weight and position to be registered on TP52 **Certificate**)
  - (5) Food and beverages in reasonable quantities for the number of crew and the duration of the race. They shall only be removed from their storage for consumption. Specifically, beverages are restricted to 2.5 liters of drinkable fluid per person per day of *racing*, in the tanks or other containers. If a *racing* day has more than one race, each race may be started with the allowed 2.5 liters per person.
- (b) NOT FOR USE OR SPECIFICALLY FORBIDDEN:
- (1) Range finding devices (other than the boat's radar) shall not be carried when *racing* unless specifically permitted by the event's NoR after consultation with the TP52 Class.
  - (2) Carrying ballast in any form, other than indicated on the TP52 **Certificate** for weight and position, is prohibited.
  - (3) Shifting any equipment from its position as indicated on the TP52 **Certificate**, other than for its primary intended use, is prohibited during *racing*.
  - (4) Hydraulic mastjack equipment (weight and position to be registered on the TP52 **Certificate**).

NOTE: Mastram(s) when racing shall never in any way be connected to the boat's hydraulic system (as used for sailing functions like headstay adjustment, etc.) or a separate pump. So the ram(s) never shall be connected to any pump when *racing*. Whether the rams are in situ, ready for operation under the mast or jacking bar, or not.

## C.6 RIG.

- C.6.1 Altering the location of the **mast** at the step or deck whilst *racing* is not permitted. However, a natural movement of the **mast** at the deck not exceeding 0.030m in the fore and aft direction, or 0.020m in transverse direction, is permitted as long as J is respected at all times. To this purpose movement of the **mast** shall be adequately restricted to not allow the **mast** to move aft of J Max = 6.200m at any time.

NOTE: Temporary chocking of the mast in any other position than its aftermost position is not permitted whilst *racing*. So alterations of J by chocking have to be **certified**. Whilst not *racing* the limits of movement without requiring remeasurement are:

- (a) At deck level, restrictions as set by J.
- (b) At the step restrictions as set by D.28.1 and along the centreline (fwd/aft movement) of plus or minus 0.015m from the point as measured with.

- C.6.2 Adjustment of **rigging** whilst *racing* is not permitted except as specifically set forth below. Otherwise, all means of adjustment must be positively locked and/or bound up to prevent accidental adjustment whilst *racing*. The following adjustment is permitted while *racing*:

- a) For purposes of safety, i.e. an exceptional adjustment of a **stay** to cure a fault.
- b) The **forestay** length may be adjusted to a maximum of 0.255 meters.
- c) **Backstays**.
- d) **Backstay** deflectors (one per backstay).

- C.6.3 Halyard Messengers are permitted while *racing*, but only to allow movement of the halyard between the sheave and the deck, not to totally remove the halyard from the **rig** when *racing*, except when replacing a damaged halyard.

**C.7 SAILS.**

C.7.1 A **boat** while *racing* shall not carry onboard more **sails** of each type than the numbers set out below:

Jibs: 4

Staysails: 1

Spinnakers: 4 (including a maximum of 1 furling spinnaker. Note: see J.6.13)

**Mainsails: 1**

Storm Trysails: 1

Storm Jibs: 1

Heavy - Weather Jibs: 1

NOTE: The specifications of storm and heavy weather sails are those of the Offshore Special Regulations Governing Offshore Racing, section 4.27. For this rule a staysail shall not be counted as a heavy weather jib for the purposes of the OSR and storm jibs, trysails and heavy weather jibs shall not be used as a staysail.

The race organizer may modify these limitations to the kind(s) and number(s) of sails appropriate to the character of the race.

C.7.2 While *racing* sail battens shall not be adjusted when a sail is set.

C.7.3 Tack Points of Jibs:

a) When a jib is set under a spinnaker or inside another jib, it shall not be tacked in such a position that, if the **sail** were trimmed flat along a parallel to the center line of the **boat**, its clew would fall abaft the LPG line (see b below).

b) The LPG line is defined as a line abaft and parallel to the headstay and separated from it by the dimension of max LPG (for this rule: 6.37m, see D.19).  
The headstay is defined as the line joining the upper measurement point of I and the forward measurement point of J.

c) No tack pennant greater than 0.75m may be used on a jib when set flying.

C.7.4 Sheeting of Jibs:

Jibs may be sheeted to any part of the working deck, but to no fixed point higher than 0.10m above the deck.

C.7.5 No jib may be set in conjunction with any other **sail** so as by any means to simulate a double clewed or double luffed jib. (For example, except when changing **sails**, two jibs shall not be carried simultaneously in a luff groove device sheeted on the same side of the **boat**.)

C.7.6 Setting of spinnakers:

Notwithstanding failure to meet the definition of a spinnaker (see J.6.1.c) a bona fide jib (see J.6.1.a) for which the **boat** has been measured may be set (tacked, hoisted and sheeted) as a spinnaker where either of the following conditions apply:

- i) In heavy weather when no other sail is set in the foretriangle and the apparent wind is abaft the beam or
- ii) When all spinnakers aboard have been damaged beyond repair during the race. A jib so set may have its tack to the bowsprit.

C.7.7 Tack position and sheeting of Spinnakers:

a) Spinnakers shall be tacked on or within 0.05m of the centreline forward of the intersection of the headstay and the deck.

b) Spinnakers shall be sheeted from only one point on the **sail**.

c) A spinnaker may be sheeted to any part of the working deck, so not to spars or outriggers.

C.7.8 Restrictions on Setting and Sheeting of **Mainsails**:

**Mainsails** shall be either secured at the **foot** or loose footed and shall remain so whilst *racing*.

A **mainsail** secured at the **foot** shall be provided with a bolt rope, track or tunnel slides, or similar **boom** attachment that prevents the **foot** from lifting away from the **boom**. A loose-footed **mainsail** shall be sheeted only from a single **clew**.

C.7.9 Storm Trysails:

These, as distinguished from loose-footed **mainsails**, must be materially smaller than a normal close-reefed **mainsail** and of a strength consistent with their purpose (use in extremely severe weather). Please note that C.7.1. requires the specifications of storm and heavy weather sails to be those of OSR 4.27.

C.7.10 Headboard Carriages:

These are permitted only if the **sail** is set and trimmed in a manner consistent with the way HB was measured.

**SECTION D - LIMITATIONS (The BOX).****D.1 MONOHULL.**

D.1.1 **Boats** under this rule shall be of the **monohull** type.

**D.2 HULL LENGTH (HL): Maximum 15.850m.**

D.2.1 **Hull Length** shall be measured including any part of the **boat's standing rigging**. Fittings extending aft of the aftermost point of the **hull** shall be added to the **Hull Length** for the purpose of this rule, except exterior chainplates if they do not extend more than 0.012m (12mm) outside the hull. Navigation lights, antennas, aft stanchions/pushpits (respecting D.7.2) and tracking devices are not to be seen as fittings for the purpose of measuring **Hull Length**.

**D.3 HULL BEAM (HB): Maximum 4.420m. Minimum at widest point 4.300m**

D.3.1 **Hull Beam** shall be measured including any part of the **boat's standing rigging**. Exterior chainplates may be excluded if they do not extend more than 0.012m (12mm) outside the **hull**.

**D.4 HOLLOW AND TUMBLEHOME**

D.4.1 **Hulls** in which the canoe body depth in any section decreases towards the centerline shall not be measured. The hull shell surface may not contain hollows except in the forward 30% of **Hull Length**. Hollows with a depth of 0.001m under 1m in length, or a depth of 0.002m over 1m in length are permitted. Spray strakes are for the purpose of this Rule to be seen as appendages and are not allowed.

D.4.2 Below the lower end of the **hull** shell to the deck joint radius the **hull** shell in any transverse section shall not increase in beam with increasing depth.

**D.5 SHEERLINE, the intersection of hull shell and deck.**

D.5.1 The **sheerline** point at any measurement station is the intersection of the top of the deck and the outside of the **hull** shell, extended as necessary, at that station. For this purpose local deflections, like bulwarks or toe rails shall be ignored.

D.5.2 For measurement purposes the **sheerline** is defined as the line passing through the **sheerline** points defined above. In **boats** where the transom slopes down and aft, the aft end of the **sheerline** shall be where the stern drops away from a straight edge placed upon the deck at the **sheerline**.

D.5.3 The **sheerline** shall be a continuous curve without double inflections in both plan and profile. In plan, both the **sheer** and the outline of the canoe body, shall have a radius of curvature greater than 10 meters.

**D.6 HULL SHELL TO DECK JOINT.**

D.6.1 The **hull** shell to deck joint from SFF to the aft end of the working deck shall have a constant radius (builders tolerance allowed +/- 2mm), chosen from a value between 0.05m and 0.08m and shall meet the **hull** tangentially. The radius shall not be bumped at the freeboard measuring points or other points, like at deck fittings or stanchion positions. Forward of SFF (around the bow) the radius shall be maintained as much as possible.

**D.7 WORKING DECK.**

D.7.1 The outermost edge of the working deck is defined as the line connecting the points where a tangent at 45 degrees can be rested on the hull shell to deck joint radius.

- D.7.2 At the stern the edge of the working deck follows the line through the center of the stanchions and/or pushpits at the local level of the **sheerline**.  
Note: Aft stanchion(s) not being the outmost stanchion or pushpit shall respect the straight line between the center of the outmost aft stanchions / pushpits at the local sheer as limit for how far aft these at their center can be positioned.

**D.8 Freeboard and Trim Points at nominal seawater:**

**Freeboard Forward (FF): Minimum 1.450m**

**Freeboard Mast (FM): Minimum 1.260m**

**Freeboard Aft (FA): Minimum 1.140m**

- D.8.1 Freeboard Points are the Sheer Points to which the flotation freeboards, FFM(measured), FMM, FDM and FAM are referenced. They shall be established by a TP52 Measurer and permanently marked at - 0.1m below the sheerline point stations near the bow, at the mast, at maximum draft and near the stern:
- The Station Forward Freeboard: SFF shall be 0.450 m (+ or - 20mm) aft of the stem.
  - The Station Mast Freeboard: SMF shall be at the forward face of the mast at deck level.
  - The Station Draft Freeboard: SDF shall be at the lowest point of the **boat**.
  - The aft freeboard station: SAF shall be established between 14.250m and 14.300 aft of the stem.

- D.8.2 Flotation Freeboard Measurements shall be adjusted to Nominal Seawater: FF, FM, FD and FA are FFM, FMM, FDM and FAM adjusted to a normalised flotation at SG 1.026 (nominal seawater).

NOTE: The **boat** is measured afloat in measurement condition for the purpose of defining "local" **measurement trim**. At the time of flotation measurement, the local Specific Gravity is measured and recorded as SG.

- D.8.3 Trim Points shall be chosen and marked on the centreline of the bow and stern, not further from floatation level than 0.5m. BTP (Bow Trim Point) and STP (Stern Trim Point) shall be recorded on the TP52 **Certificate**.

**D.9 BOAT WEIGHT (DSPM): Minimum 6975kg.**

- D.9.1 The **boat** shall be weighed in measurement condition with a certified loadcell. Each Owner shall be responsible for loadcell rental as part of the measurement expense. The loadcell shall have been calibrated in the last 6 months and shall have increments not larger than 5.0 kg. The TP52 Measurer shall verify the **boat** is offered for weighing conform the TP52 Rule and execute / observe the weighing. The **Boat Weight** shall be recorded in the TP52 Certificate as DSPM.

**D.10 DRAFT (D): Maximum 3.500m at SG 1.026.**

- D.10.1 **Draft to Sheer (DTS)** and Freeboard Draft Measured (FDM) shall be measured. DTS is the vertical distance from the lowest point of the **boat** to the **sheerline** at the same section, and FDM is the freeboard measured at the same section. The distance from the bow to the maximum draft section shall be recorded as SDM. The **Draft** of the boat shall be calculated as follows: **Draft** = DTS - FDM.

**D.11 KEEL BOX.**

- D.11.1 **Bulb Weight (BW):** Maximum 3800kg (**bulb** shall be weighed with filler and paint, the weight shall include all ballast in case the **bulb** has (a) ballast pocket(s).  
**Bulb Volume (BV):** Minimum 345 liter.  
**Keel Weight Total (KWT):** Maximum 4600kg (**bulb**, ballast and **fin** assembled, faired and painted).  
**Keel Width (KWM):** Maximum 0.65m. The **keel** shall be measured in the transverse axis and the largest measurement shall be recorded.  
**Bulb Height (BHM):** Minimum 0.38m. The **bulb** shall be measured in the vertical axis and the largest measurement shall be recorded. The radius into the **fin** shall be ignored for this measurement.  
**Bulb Shape:** In any direction no hollows larger than 5% (5cm over 1m) other than in the radius where the **bulb** meets the **fin**. Building irregularities will be accepted, subject to the judgement of the Chief Measurer.

**D.12 MAST AND BOOM WEIGHT: Minimum Mast 235kg, Minimum Boom 30kg.**

- D.12.1 **Mast** and **boom** shall be weighed with a certified loadcell at the single point of their center of gravity in measurement condition. Each Owner shall be responsible for loadcell rental as part of the measurement expense.  
The loadcell shall have been calibrated in the last 6 months and shall have increments not larger than 1.0 kg. The TP52 Measurer shall verify that **mast** and **boom** are in measurement condition and execute / observe the weighing. The weighed measurements shall be recorded in the TP52 Certificate as MWT and BWT.

- D.12.2 All measurements above shall be taken with the components dry and the spars fitted only with components with which the **boat** will actually *race* as specified below:

- (a) The **mast** shall be completely rigged with **standing rigging, spreaders, deflectors, lights, antennae, wiring, luff groove device** and all other permanently attached fittings, including those turnbuckles which are not permitted to be adjusted while *racing*.

In measurement condition the **mast** may have a permanently fitted internal hydraulic mastjack ram. Note: The total **mast** corrector weight (if required) shall be 10.0 kg or less.

NOTE 1: A genuine mastboot and/or Spartight or similar permanent chocking fixed to the **mast** may be included in the mast weight. This fully to the judgement of the measurer. An estimated weight for these components shall be noted on the input form. A lower pendant of the **forestay** shall not be part of the rig weight. A lower pendant shall not extend above 1.0m from the local **sheer** with the headstay ram fully extended.

- (b) Excluded for measurement shall be **running rigging, rigging adjusters** of any type (hydraulic or otherwise) and any associated blocks and tackle, boomvang and reefing tackle. Halyard messengers of not more than 4mm diameter and weighing not more than 15 grams per meter and only sufficient for convenient releading may be used to replace internal portions of **running rigging**.
- (c) All wiring, messengers and **standing rigging** shall be in their proper attached positions, and any slack stretched down and secured along the length of the **mast** with light material, such as lanyards or tape, with any tails hanging free at the butt.
- (d) Headboard, luff slides and any other adjustable devices shall be at their lowest limit of travel.
- (e) The **boom** shall be without its gooseneck toggle, jammers, lines, block and tackle and/or hydraulic hoses/tubes (max 4mm messengers allowed), rams, outhoul / clew straps, cars.

NOTE 2: The total **boom** corrector weight (if required) shall be 1.0 kg or less. The intention is to promote a structurally competent **boom**, unusual constructions going against this intention may be reason to refuse **certification**.

- D.13 MAST CENTRE OF GRAVITY (MCG): Minimum height above sheer 9.350m.**  
 D.13.1 The TP52 Measurer shall verify the center of gravity of the **mast** in its measurement condition. The MCG shall be recorded in the TP52 **Certificate**.
- D.14 MAST FORE AND AFT DIMENSION: Minimum (0.280m) and Maximum (0.340m).**  
 D.14.1 The TP52 Measurer shall verify the minimum and maximum **mast** fore and aft dimensions, MDLmin and MDLmax. MDL at no point between deck and the **forestay rigging point** shall be under 0.280m or over 0.340m. MDLmin and MDLmax shall be recorded in the TP52 Certificate. The topmast up to P (Upper Point) shall not be less than 0.150m. At no point the mast on the nose centerline between P and the forestay rigging point shall be hollow, so not be under an imaginary straight line between those points, except for construction imperfections.
- D.15 MAST TRANSVERSE DIMENSION: Minimum 0.130m.**  
 D.15.1 The TP52 Measurer shall verify the minimum **mast** transverse dimension, MDT. MDT at no point between deck and the Forestay Point shall be under 0.130m and shall be recorded in the TP52 Certificate. The topmast up to P (Upper Point) shall not be less than 0.100m.
- D.16 FORETRIANGLE HEIGHT (I): Maximum 19.720m**  
 D.16.1 **Foretriangle Height** is the distance between the **forestay rigging point** and the **mast datum point**, which for the purpose of this rule is the **sheer** at SMF. The **forestay rigging point** is the intersection as shown in ERS F.2.3.d. For this purpose the forward side of the **mast** shall be established disregarding any local reinforcement.  
 D.16.2 (I) shall not be extended by any device or means.
- D.17 JIB HEAD LIMIT MARK (IGC):**  
 D.17.1 IGC shall be the maximum height to which the **head** of a jib shall be hoisted.  
 D.17.2 IGC shall be marked on the front of the **mast** till the middle of the **mast** in that section with a contrasting 0.025m wide (white or black) band at a level of 0.420m below I.
- D.18 FORETRIANGLE BASE (J): Maximum 6.20m.**  
 D.18.1 The **Foretriangle Base** is the longitudinal distance between the intersection of the fore side of the **mast** and the deck, and the intersection of the centerline of the **forestay** and the deck. In case the deck at the point of intersection is below the **sheerline** in this station, the intersection shall be taken to the **sheerline**. The **mast** shall be in its aftermost point and upright when taking this measurement.  
 D.18.2 (J) shall not be extended by any device or means.
- D.19 LUFF PERPENDICULAR Headsail (LP): Maximum 6.300m.**  
 D.19.1 **LP** is the shortest distance between the **clew point** and the **luff**.

D.19.2 For this rule there is a maximum  $LPG = LP + FSP = 6.38m$ . FSP is twice the maximum dimension, measured in the transverse axis, of a luff support device. Any permitted device on the headstay other than hanks shall be measured for FSP.  
NOTE: FSP Maximum 0.080m. A feeder/pre-feeder cover may exceed this width, but only if it is not longer than 0.40m.

**D.20 JIB TOP WIDTH (HHB): Maximum 0.15m**

D.20.1 **HHB** is the distance between the **head point** and the **aft head point**.

**D.21 JIB LUFF LENGTH (LL): largest dimension to be recorded.**

D.21.1 **LL** is the distance between the **head point** and the **tack point**.

**D.22 SAIL WIDTHS:** JGT (HUW) Maximum 1.00m, JGU (HTW) Maximum 1.80m, JGM (HHW) Maximum 3.25m.

D.22.1 Mainsail and Jib and Staysail Widths: The shortest distance between the **leech points** and the **luff**.

D.22.2 Spinnaker Widths: The distance between **leach point** and corresponding **luff point**.

D.22.3 Intermediate sail widths values between **clew** and **head** shall proportionally not be above the values at the recorded widths. Jibs shall not have any form of “disproportional leach hollows or recesses”, or “local cloth choices” accommodating going around spreaders.

**D.23 SPINNAKER HOIST HEIGHT (ISP): Maximum 22.400m.**

D.23.1 **Spinnaker Hoist Height** is the distance between the **mast datum point**, which for the purpose of this rule is the **sheer** at SMF and the lower edge of the spinnaker halyard, when at 90° to the spar.

D.23.2 ISP shall not be extended by any device or means.

**D.24 BOWSPRIT LENGTH (STL): Maximum 9.000m.**

D.24.1 **Bowsprit** Length is the longitudinal distance from the intersection of the foreside of the **mast** and the deck to the outer end of the **bowsprit**. The **mast** shall be in its aftermost point and upright when taking this measurement.

D.24.2 STL shall not be extended by any device or means. However a single device, extending STL by no more than 0.75m in its most forward position, of which the sole purpose is to prevent spinnaker sheets to fall into the water and possibly get under the bow may be fitted. This device may be retractable, but it shall never be retracted or extended for other purposes than its sole intended use as sheet catcher.

**D.25 MAINSAIL HOIST (P): Maximum 20.400m.**

D.25.1 **Mainsail** Hoist is the distance along the mast between the **Lower Limit Mark**, which shall be identical to the **Boom** Position (BAS), and the **Upper Limit Mark**.

**D.26 MAINSAIL FOOT (E): Minimum 7.000m.**

D.26.1 **Mainsail Foot** is the distance, with the **boom** on the **mast** centreplane and at 90 degrees to the **mast**, between the aft side of the **mast** including any external track or groove, or its fair extension parallel to the axis of the **mast**, to the **Boom Outer Limit Mark**. Any part of the **mast** which extends abaft the aft side of the track or **mast** groove shall be ignored in determining E.

**D.27 MAINSAIL TOP WIDTH (MHB): 2.000m.**

- D.27.1 **Mainsail Top Width** is the distance between the **Head Point** and the **Aft Head Point**. The actual top width shall be 2.000m or less. The area calculation shall use either 1.800m or the actual value if between 1.800m and 2.000m.  
NOTE: A TP52 shall have a square top **mainsail** meaning that the angle between the luff and head edges shall be 90 degrees or less than that bridging the forward and aft **head points** and luff curve as necessary. No part of the **sail** shall be above the 90-degree line.

**D.28 BOOM POSITION (BAS): Minimum 2.100m, Maximum 2.130m.**

- D.28.1 When the **boom** is horizontal the top of the **boom** (including an external groove or track) shall be on the same level as the upper edge of the **Lower Limit Mark** (mast vertical in boat).  
The Boom Position is the distance between the **sheer** at SMF and the upper edge of the **Lower Limit Mark** (*please note: for measurement purposes, if the mast cannot be put vertical in the boat, BAS will be established from measuring the distance from the top of the Lower Limit mark to the bottom of the mast and the distance from the top of the mast step to the sheer at SMF to establish the maximum shim stack height to get to max BAS (2.130). The max shim stack height or if requested by the owner a lower max shim stack height (no lower than 2.120m) shall be recorded on the TP52 Certificate.*)  
The maximum adjustment downwards when not *racing* (without applying for remeasurement), allowed from the max shim stack height as measured/chosen, adjusted when not *racing*, is 0.020m (20mm).  
NOTE: A TP52 shall only be measured with BAS in the position as recorded on the TP52 Certificate.

**D.29 BOOM DEPTH (BD): Maximum 0.36m.**

- D.29.1 Depth (vertical cross section) including any sail groove or sail track but excluding other fittings. A "gooseneck cover" may be fitted but only if within the limits of D.29 till the cover is on the mast.

**D.30 MAINSAIL AREA (MSA): Maximum 98.000m<sup>2</sup>.****D.31 HEADSAIL AREA (HSA): Maximum 66.000m<sup>2</sup>.****D.32 SPINNAKER AREA (ASA): Maximum 270.0m<sup>2</sup>.****D.33 V1 SHROUD BASE (CPW): Minimum 3.500m.**

- D.33.1 CPW shall be the distance between the centers of the bearing points of the chainplates for the upper shrouds of the main mast.

**D.34 SPEED UNDER POWER: Minimum 7 knots.**

- D.34.1 Speed Under Power minimum 7 knots. With racing propeller, in smooth water and without assistance of wind.

**SECTION E - HULL.****E.1 GENERAL.**

E.1.1 The structural integrity of a **boat** is the responsibility of the competitor. Compliance with this Rule and its requirements does not relieve the competitor from ensuring the **boat** is of adequate strength.

E.1.2 For the purpose of Section E Hull Shell means the fair body of the **boat** up to the edge of the working deck (see D.7.1). Deck means the upper surface of the **boat** inside the edge of the working deck, including transom, coachroof and cockpits. The Internal Structure means all structural elements inside hull shell and deck.

E.1.3 A **hull** shall not be loaded or deformed by any device or means other than by normal loads imposed by the sea and/or rigging arrangements allowed within this Rule.

**E.2 CERTIFICATION.**

E.2.1 A **boat** shall meet the TP52 Rule, the WS OSR Category 1 for sections 1, 2 and 3 of the OSR as well as the latest version of the DNV Standard for TP52 **boats** (DNV-TP52).

E.2.2 Plan approval is required and shall be done by the DNV Standard 0490, TP52 racing yachts. The TP52 Class and DNV will agree on which components of the TP52 Rule are part of the plan review by DNV.

E.2.3 The plans shall be checked and if approved marked as such by DNV and the Builder shall provide a signed declaration that the boat has been built in accordance with those plans.

E.2.4 Within the confidentiality that DNV agrees with their clients, specific for plan approval of TP52 **boats**, it shall be allowed to share details of the plans under review with the TP52 Class Manager for the sole purpose of plan approval related matters. In that case the TP52 Class Manager is bound by the same confidentiality limitations as DNV.

**NOTE 1: E.2.4 shall not be excluded in the DNV-client confidentiality agreement. Such an exclusion will be sufficient reason to withhold the TP52 Certificate.**

**NOTE 2:** The Class Manager may decide to ask a class member to permit taking one or more samples of hull and/or deck to check for compliance with the TP52 Rule. Upon request the Class Manager shall indicate his reasons for such a request and the class member may appeal the request with the TP52 ExCom. The TP52 ExCom may take advice of the Technical Committee which for this occasion shall not include the Class Manager. The TP52 ExCom decision is final. The cost of taking and processing the samples is for the TP52 Class. The costs of repair of the boat, no matter the outcome of the test, is for the boat owner / class member.

E.2.5 The TP52 Chief Measurer shall certify the hull on the TP52 Certificate.

- E.2.6 The Owner and / or the Designer shall submit the plans that will be used for the construction of the **boat** to DNV:  
 DNV, Department: Hull  
 Brooktorkai 18  
 20457 Hamburg,  
 Germany

Alternatively the drawings can be submitted in electronically form via DNV's "MyDNV" server. Additional information to be found under the following link:  
<https://www.veracity.com>

NOTE: A **boat** shall meet WS OSR Category 1 for sections 1, 2 and 3 of the OSR includes that the **boat** shall be constructed according to ISO 12215 Category A.

The scope of the plan review consists of application and calculation to the following parts of ISO12215 - Small Craft - Hull construction and scantlings:

- ISO 12215 Part 5: Design pressures for monohulls, design stresses, scantlings determination. All parts and annexes where applicable to design category A ("ocean") - Sailing Craft - ISO 12215 Part 8: Rudders. All parts and annexes where applicable to design category A ("ocean")
- ISO 12215 Part 9: Appendages and rig attachment. Appendages only – Parts 1 to 7, Annex A, B, C, F where applicable to design category A ("ocean")

Criteria:

- a) The **boat** shall show complete compliance with the above ISO standard parts.
- b) In all applicable cases the ISO standards should be applied as the minimum.
- c) Any interpretation of the ISO standard shall be as confirmed by WS.
- d) The latest version of the ISO standard shall be used at all times.
- e) There is no building inspection or site visits. The review is plan based only.

With d): For the purpose of the TP52 Rule the latest version of the ISO standard is the version in force at the time Plan Approval is granted, for the duration of the construction of the **boat**. Provided that construction starts not later than 90 days after the date of Plan Approval and finishes within 400 days from that date.

### **E.3 MODIFICATIONS, MAINTENANCE AND REPAIR.**

- E.3.1 Hull Shell, Deck and Internal Structure shall not be altered in any way except as permitted by these class rules.

- E.3.2 Routine maintenance is permitted without remeasurement and recertification.

### **E.4 MATERIALS AND CONSTRUCTION.**

- E.4.1 Hull shell, deck and internal structure shall be made of FRP laminates complying with the following:
- a) Fibres used shall have a fibre modulus less than 250 GPa by SACMA SRM 16 / ASTM D4018 / ISO 10618 / JIS R 7608 measured between 1000 and 6000 microstrain.
  - b) Individual laminate plies used for hull, deck or structures laminates shall be of a minimum of 100 gram dry fibre weight.
  - c) Cores shall be of wood, plastic foam or (Meta) Aramid Fibre paper honeycomb coated with a heat resistant phenolic resin. Specifically, the so-called Para Aramid Fibre honeycombs based on N636 paper are not permitted under this rule.  
 Aluminum alloys of the 5000 and 6000 series, titanium, steel or stainless

steel alloys may be used for tapping plates, backing plates, etc.

- d) The cure process shall be based on applying external heat of less than 105 degrees Celsius.
- e) Pressure applied at any time during construction shall be less than 1 Atmosphere.  
NOTE: this shall not prevent the use of construction methods using clamps, mechanical fastenings, wrapping, winding, etc.
- f) Commercially available stock materials like plates and tubes constructed in excess of the limits on temperature and pressure as specified in this rule may be used for small components, but their use has to be approved in writing by the TP52 Chief Measurer.
- g) Fastenings, like screws, rivets, bolts, nails, may be used if made of steel, stainless steel or titanium.
- h) Chainplates, keel and rig related structural components shall be made of FRP laminates, or steel, stainless steel, titanium or aluminum alloys of the 5000 or 6000 series. Builders shall provide upon request by a TP52 Measurer all relevant information on the materials and methods used to build the boat.

#### E.4.2 Skin minimum requirements:

- a) Hull shell Outer skin min dry fibre weight 1.300kg/m<sup>2</sup>
- b) Hull shell Inner skin min dry fibre weight 0.900kg/m<sup>2</sup>
- c) Deck Outer skin min dry fibre weight 0.800kg/m<sup>2</sup>
- d) Deck Inner skin min dry fibre weight 0.550kg/m<sup>2</sup>
- e) Transom Outer skin min dry fibre weight 1.000kg/m<sup>2</sup>
- f) Transom Inner skin min dry fibre weight 0.700kg/m<sup>2</sup>

#### E.4.3 Hull shell and deck core minimum requirements:

- a) Hull shell core forward of mast (J) and below WLP+0.20m:  
minimum thickness: 25mm, minimum weight: 3.25kg/m<sup>2</sup>
- b) Hull shell core forward of mast (J) and above WLP+0.20m:  
minimum thickness: 25mm, minimum weight: 2.4kg/m<sup>2</sup>
- c) Hull shell core aft of mast (J), below WLP+0.200m up to stern section (at least 1.0m behind the rudder position) and in mast area:  
minimum thickness: 20mm, minimum weight 1.6kg/m<sup>2</sup>
- d) Hull shell core aft of mast (J), above WLP+0.200m and stern section except transom: minimum thickness: 20mm, minimum weight 1.28kg/m<sup>2</sup>
- e) Transom core: minimum thickness 20mm, minimum weight 0.96kg/m<sup>2</sup>
- f) Deck core (excl. cockpit sides/front): minimum thickness 20mm, minimum weight 0.96kg/m<sup>2</sup>
- g) Cockpit sides/front core: minimum thickness 10mm, minimum weight 0.48kg/m<sup>2</sup>

NOTE 1: The combination of minimum thickness and weight is put in place to allow flexibility in design on the cores. This mainly will open the door to diversity in the bow where in the slamming area the minimum set allows for choices like 130kg foam at 25mm, 96kg nomex at 34mm or 100kg foam at 33mm. Behind the mast the minima relate to 64 and 80 kg/m<sup>3</sup> nomex. The deck minima relate to 48kg/m<sup>3</sup> nomex.

NOTE 2:

- Cores may be tapered below the given limits and single skin areas are excluded from the minimum thicknesses as given. In that case the minimum weight of a single skin or "tapered core" panel shall be equal or exceed 1.5 times the surrounding panel weight.

- Cores may be formed by several layers of core of equal density as given as the minimum, as long as the total core thickness corresponds with the minimum requirement.
- Core dimension and density may vary from the given values, but such a variation shall not result in a lighter solution than given in this rule as a minimum requirement.
- In case a variation is sought that goes lighter on the given minimum core requirements, based on putting in place more internal structure than required with the given core values of this rule, such a variation shall solely be given Plan Approval if it results in at least an equal weight and vcg hull to the TP52 Rule minimum requirements option. The designer shall supply the calculations supporting the application.

NOTE 3: Possibility of outer skin of damage.

Please note that the listed minimum deck skin weight requirements belong to the ISO standard which additionally requires a warning statement: *"The outer skin of your boat is not designed to resist local damage from hitting hard/sharp objects. If the outer skin is damaged, it shall be repaired immediately."*

**NOTE 4: Limits as set by this rule aim to result in hulls of more or less equal weight and vcg. The limits may not be adequate from the point of structural requirements. Specific engineering should be completed for each individual design.**

- E.4.4 Internal structure additional requirements:  
One "semi watertight" full section bulkhead/ringframe (closed up to 0.5m above WLP and above that plane of at least 0.1m width) required between 2.25m and 2.35m from bow. One centerline drainhole allowed (with plug on lanyard in situ).
- E.4.5 No **boat** shall use any material having a density greater than that of lead (11.30 kg/dm<sup>3</sup>) as ballast in any form or location on or within the **boat**.
- E.4.6 The hull shell (outside) shall at least be coated with a primer (also see E.4.7). The deck (outside) shall at least be coated with a primer and where appropriate for safe and proper working reasons with a primer or topcoat/non-skid combination. Other choices to be presented to the TP52 Chief Measurer for approval.
- E.4.7 **Boats** shall not have a specially textured surface on the hull shell, or devices on or near the surface of the hull shell, or any other kind of method of modifying the flow characteristics of water in the boundary layer of the hull shell, of which the purpose is, or could be, to reduce drag. Only paint systems using two-component linear polyester saturated aliphatic polyurethane or two component acrylic urethane shall be applied.
- No materials other than specified manufacturer supplied retardants, accelerants, thinners and pigments shall be added. The specific gravity of the paint shall not be altered with any material other than specified above. Other choices to be presented to the TP52 Chief Measurer for approval.
- E.4.8 Vinyl-film application on the painted hull shell is permitted for advertising (including private logo/striping, etc.) reasons only. Below 0.2m above the waterline it shall be covered by a paint system complying with this rule. The vinyl used shall not be textured in any way.

- E.4.9 The outermost surfaces of the hull shell may be sanded and/or cleaned with normal concentrations and quantities of detergents or similar materials and/or coated / polished with non-customized off the shelf products available on the open market like HullKote. On a race day no substances shall be present on the outermost surface of the hull shell than those permitted in E.4.7 - E.4.9.

## E.5 REQUIREMENTS.

### Hull.

- E.5.1 Interior ballast shall be fitted inside the “proper hull” of the **boat** in such a way that it is not a structural part of the **boat**, is easily removable without damaging the hull or internal structure of the **boat** and is not covered or fitted in a way that makes checks and inspections impossible or difficult to execute.
- E.5.2 Water ballast is not permitted.
- E.5.3 All **boats** shall be capable of being lifted from a single point. **Deck.**
- E.5.4 Forward of 8.75m aft of the stem the entire **hull** shell shall be decked, except for hatches and small openings as specifically permitted by this rule. Aft of 8.75m aft of the stem the upper surface can be deck or cockpit.
- E.5.5 The deck shall have positive camber (going inboard from the **sheerline** to the centerline the deck has to go up at all points, measured between the sheer points). Camber shall not be less than 2%, so going inboard from the **sheerline** the deck at no point shall be lower than the local sheer + the intermediate value based on a rise of 2cm/m.

Recesses below the 2% camber requirement are not allowed except for a recess in the bow area to facilitate lowering the jib tack fitting. This recess shall not be larger than 0.015m<sup>3</sup> (measured in measurement trim to the level of the aft outer ends of the recess) and have adequate means of draining water to the sea as well as providing a watertight construction. The bow recess may have a (flexible) cover.

Recesses or cut-outs specifically for winches or fittings are allowed but only for standard (of the shelf) deck equipment. In case of doubt get written permission by the TP52 Chief Measurer. See E. 5.7 and E.5.13.

- E.5.6 Minor transverse hollows as result of building irregularities are permitted, but these shall not exceed 0.003m in 1.0m and a maximum of 0.005m over any length.
- E.5.7 Recesses or cut-outs for winches or fittings shall produce a 100% watertight combination.
- E.5.8 There shall be at least one main entrance hatch aft of the mast. The hatch or hatch / washboard combination shall not extend below 0.3m from the local cockpit floor or be at or over local **sheerline** level. The hatch, if sliding, may be recessed. In the sense that it slides under the deck.
- E.5.9 There shall be a single hatch forward of the mast, which is for safety reasons advised to open forward by sliding or hinging. The hatch, if sliding, may be recessed. In the sense that it slides under the deck.

- E.5.10 Hatches without their hinges, slides or locking mechanisms shall not be lighter than the area they replace under this rule.
- E.5.11 Hatches shall be watertight. This shall be tested by a TP52 Measurer with a hose aiming at the hatch from any direction.

**Cockpit.**

- E.5.12 The cockpit floor shall not have negative camber. At the stern in measurement trim the lowest level of the cockpit floor shall not be lower than 0.45 meter below the local sheer. From there the cockpit floor shall have a forward positive slope of at least 1.5%, so rise at least 15 mm over 1 meter.
- E.5.13 Winches shall be deck mounted or positioned on cockpit pods. If deck mounted they may be recessed, in which case the entry position of the rope on the winch drum shall not be any lower than the local deck. A pod placed winch shall have a pod not lower than 0.3m from the local cockpit floor. A single pit winch may be recessed in the deck together with the associated equipment, like jammers, to suit the line entry position on the winch to be no lower than local sheer (see G.5.1.7). Deck mounted winches, whether recessed or not shall not be covered to such an extent that a rope cannot be placed on, operated, or taken off the winch without that this deforms a (flexible) cover or requires a cover to be operated (like hinged, sliding, etc). The pit winch recess may have a cover but the winch itself shall not be covered.

NOTE: In general jammers and other equipment may be recessed, pocketed, etc. as long as the position and size of the recess / pocket / etc is in line with the primary function of the equipment and the equipment can be handled from deck with the hatches closed.

- E.5.14 Cockpits shall be watertight, except that they shall self-drain overboard in measurement condition/trim at all heel angles between zero and thirty degrees. Small openings for control lines are permitted, but only if via a proper watertrap arrangement accepted by the TP52 Chief Measurer.
- E.5.15 Hatches are not permitted in the cockpit floor. Hatchpods or the lowest opening of portlights or similar mounted in a cockpit- or podsides shall have a minimum height of 0.2m from the local cockpit floor. Any hatch shall have a hinged or screwed watertight cover attached to the hatch.
- E.5.16 All **boats** shall have the provision to carry canister liferafts on deck as near to the stern as practical. Liferaft storage belowdecks for the purpose of this rule is prohibited.

**Small Openings and the Mast Collar.**

- E.5.17 Small openings in deck and cockpit for passing rigging or lines are permitted provided:
- (a) They are no larger than required for their specific task.
  - (b) They are made watertight by a rubber boot, tube and/or watertrap arrangement that passes the hose test by a TP52 Measurer.
  - (c) The mast collar specifically shall be sealed to withstand the hose test by a TP52 Measurer.

**SECTION F - HULL APPENDAGES.****F.1 GENERAL.**

- F.1.1 A TP52 shall be fitted with one fixed centerline **keel**, solid in profile, which shall have a **bulb**, one centerline rigid-surface **rudder**, one bona fide propeller installation and the usual instrument transducers.
- F.1.2 **Boats** having any other **hull appendages**, or what can be described as a dynamic ballast system of any sort, shall not be measured.
- F.1.3 A **keel** is classified as fixed when no part of the **keel** is adjustable when racing so as to alter the yacht's **maximum draft** and when the **keel fin** is attached to the **hull** in such a way that it does not move beyond the normal elasticity of the materials used, and cannot be moved, when sailing. Consequently, the **keel** may not have a **trim tab**.
- F.1.4 The **keel** and/or **rudder** may have weed a knife and fairing for the weed knife. The weed knife may only travel in the centerline vertical plane of the leading edge of the **keel** or **rudder** and the weed knife system is permitted to be of any of the materials permitted for construction and equipment of the **boat**.
- NOTE: the installation of a weed knife in the keel will most likely interfere with the rule on voids and cavities (F.1.7). This is permitted if the weed knife installation clearly is not serving any other purpose than required for its primary function as weed knife.
- F.1.5 The **rudder** may not be multi surface (shall have a single blade without endplates or similar) and its axis of rotation shall be in the centreplane of the **boat**.
- F.1.6 A **hull appendage** may extend into the **hull**, however the TP52 Chief Measurer shall be satisfied that it is designed solely to attach the **hull appendage** to the **hull** and not to significantly contribute to the strength or stiffness of the **hull**. The **hull appendage** shall be able to be removed without damaging the structural integrity of the **hull**.
- F.1.7 Voids or cavities are not allowed in the **bulb** (other than the pockets of F.4.3) and the **keel fin** (below the outside of the hull and above the outside of the bulb).  
NOTE 1: For the purpose of rule F.1.7, where it concerns the keel fin between the outside of the hull and the outside of the bulb, to further define the holes, pockets, voids, cavities not permitted, these concern any space located in the fin in such a way that when drilling a hole at 90 degrees anywhere to the longitudinal axis of the fin one would hit steel before getting to the holes, pockets, voids or cavities. Except that in the front (nose) and back of the structural component a slot may be milled if parallel or tapered towards the centerline of the structural component's longitudinal axis (see sketches).  
NOTE 2: It is strongly advised to clear appendages in the design stage with the class manager for rule compliance. If not and found not in compliance appendages build after 1 January 2019 will not be certified, also not on basis of any form of compensation or penalty.
- F.1.8 **Hull appendages** shall comply with the **class rules** in force at the time of initial certification.

**F.2 CERTIFICATION**

F.2.1 The **hull appendages** shall meet the TP52 Rule, the WS OSR Category 1 for sections 1, 2 and 3 of the OSR as well as the latest version of DNV Standard for TP52 **boats** (DNV - TP52) and be constructed accordingly.

F.2.2 The Owner and / or the Designer shall submit the plans that will be used for the construction of the **hull appendages** to the DNV, the TP52 Class Recognised Body, for Plan Approval.

F.2.3 The plans shall be marked as approved by DNV and the Builder shall provide a signed declaration that the **boat** has been built in accordance with those plans.

F.2.4 The TP52 Chief Measurer shall certify the **hull appendages** on the TP52 Certificate.

**F.3 MODIFICATIONS, MAINTENANCE AND REPAIR.**

F.3.1 **Hull Appendages** shall not be altered in any way except as permitted by these class rules.

F.3.2 Routine maintenance is permitted without remeasurement and re-certification.

**F.4 MATERIALS AND CONSTRUCTION.**

F.4.1 The sole permitted material for the keel fin's structural component and structural quality is steel or stainless steel and the permitted materials for the keel bulb are lead, antimony or it's alloy's (max 4%), steel and stainless steel.

F.4.2 The keel fin between the outside of the hull and the outside of the bulb may be brought up to its final shape and faired into the hull and bulb by any material with a specific gravity lower than or the same as steel. Fibres used shall have a fibre modulus less than 250 GPa by SACMA SRM 16 / ASTM D 4018 / ISO 10618 / JIS R 7608 measured between 1000 and 6000 microstrain.

NOTE: Consequently, any material with a specific gravity lower than steel (F.4.1) cannot be used to fill holes, cavities, etc. which do not (direct or indirect) contribute to the shape (external form or outline) of the keel fin (see sketches with F.1.7 for how this is limited to holes 90 degrees to the longitudinal axis and slots parallel or tapered towards the centerline of the structural component's longitudinal axis).

F.4.3 The **bulb** may have one **fin** pocket, ballast pocket(s) and bolt/nut/washer pockets. A **fin** pocket is intended to house solely the genuine attachment flange or stub of the **fin** and shall have a maximum volume of 0.010m<sup>3</sup> (10 liter). No part of the **fin** that is inside the **bulb** outline when **bulb** and **fin** are fitted together, or in fact forms a part of the **bulb** outline and thus volume (to judgement TP52 Chief Measurer) shall exceed the volume of 0.010m<sup>3</sup>. In this volume also steel or stainless steel spacer or filler plates and the fastenings and washers required to fit **bulb** and **fin** together are allowed. A bolt/nut/washer pocket shall be no larger than the size required to properly fit and tighten the bolt/nut/ washer(s) combination. Bolt, nut and washer(s) shall have a realistic dimensional relation to their primary purpose. Overdimensioned items, clearly intended to add unmeasured weight, will not be accepted. Bolt/nut/washer pockets may be filled up with a lead/filler mix before fairing the surface in with the **bulb**. The lead used for this purpose will have to be declared to the measurer and added to the **bulb** weight as ballast weight!!!

NOTE 1: To facilitate racing at either 3.50 meter or 3.35 meter draft the **fin** pocket may be extended vertically by 0.15 meter. At 3.50 meter draft the required spacer may be made of lead or steel and shall be part of the **bulb** weight.

NOTE 2: One ballast pocket may be situated in such a way that it forms in fact one unit with the **fin** pocket. This unit may be used to create various **bulb** positions related to the **fin**, so in fact various **fin** pocket positions.

- F.4.4 The **bulb** may have (a) ballast pocket(s).  
Note: The pocket(s) shall be filled with lead during measurement to assess the max weight of the **bulb**. If the **bulb** is not to be certified at its maximum weight the to be certified weight shall be taken as well and the position of the ballast and void(s) noted.
- F.4.5 The **rudder** shall be made of FRP laminates complying with the following:
- F.4.6 Fibres used shall have a fibre modulus less than 250 GPa by SACMA SRM 16/ASTM D 4018 / ISO 10618 / JIS R 7608 measured between 1000 and 6000 microstrain.
- F.4.7 Cores shall be of plastic foam or (meta) aramid fibre paper honeycomb coated with a heat resistant phenolic resin. Aluminum alloys of the 5000 and 6000 series, titanium, steel or stainless steel alloys may be used for tapping plates, backing plates, etc. Specifically lead may be used for so-called vibration dampers if not heavier than 50 grams per damper and a total weight of the dampers of 0,600kg. Vibration dampers shall only be installed with class approval in writing.
- F.4.8 The cure process shall be based on applying external heat of less than 135 degrees Celsius.
- F.4.9 Pressure applied at any time during construction shall be less than 7 Atmospheres.  
NOTE: this shall not prevent the use of construction methods using clamps, mechanical fastenings, wrapping, winding, etc.
- F.4.10 Fastenings, like screws, rivets, bolts, nails, may be used if made of steel, stainless steel or titanium.
- F.4.11 Builders shall provide upon request by a TP52 Measurer all relevant information on the materials and methods used to build the **hull appendages**.
- F.4.12 **Hull appendages** as far as they are part of the underwaterbody shall at least be coated with a primer.
- F.4.13 **Boats** shall not have a specially textured surface on the **hull appendages**, or devices on or near the surface of the **hull appendages**, or any other kind of method of modifying the flow characteristics of water in the boundary layer of the appendages, of which the purpose is, or could be, to reduce drag. Only paint systems using two-component linear polyester saturated aliphatic polyurethane or two component acrylic urethane shall be applied. No materials other than specified manufacturer supplied retardants, accelerants, thinners and pigments shall be added. The specific gravity of the paint shall not be altered with any material other than specified above. Other choices to be presented to the TP52 Chief Measurer for approval.

- F.4.14 The outermost surfaces of the **hull appendages** may be sanded and/or cleaned with normal concentrations and quantities of detergents or similar materials and/or coated / polished with non-customized off the shelf products available on the open market like HullKote. On a race day no substances shall be present on the outermost surface of the **hull appendages** than those permitted in F.4.13 - F.4.14.

**SECTION G - INTERIOR, ENGINE AND PROPELLOR.****G.1 GENERAL.**

- G.1.1 The purpose of this section is to ensure that all **boats racing** under the TP52 Rule meet minimum interior standards in order to provide for equal opportunities racing.
- G.1.2 A **boat** shall not race unless she complies with the interior, engine and propellor requirements.
- G.1.3 All systems relating to living, eating, sleeping, and stowage as well as propulsion specified in this section shall be arranged in a manner suitable for use at sea and shall operate to provide the service function normally associated with the system. Items shall be presented as they are intended to be used.

**G.2 CERTIFICATION.**

- G.2.1 A **boat** shall meet WS OSR Category 4 for the interior and engine (installation) requirements as well as comply with the following Offshore Special Regulations (C.5.1):
- 3.17.1 Toe rail
- 3.23.1.b One permanently installed manual bilge pump operable with all hatches shut.
- 3.28.1.b Minimum speed under engine. See D.34.
- 3.28.1.d Fuel systems requirements.
- 3.28.4 Battery systems requirements.
- 3.29.2 VHF requirements (also see C.1.2.3).
- 4.05.2 Two fire extinguishers of minimum weight 2kg each. 4.15 Emergency steering.
- G.2.2 The TP52 Chief Measurer shall certify the interior and engine (installation) on the TP52 Certificate.

**G.3 MODIFICATIONS, MAINTENANCE AND REPAIR.**

- G.3.1 The interior and engine (installation) shall not be altered in any way except as permitted by these **class rules**.
- G.3.2 Routine maintenance is permitted without remeasurement and re-**certification**.

**G.4 MATERIALS AND CONSTRUCTION.**

- G.4.1 Non-structural internal components may be made of any of the permitted materials for hull shell, deck and internal structures, as well as of aluminum alloys of the 5000 and 6000 series, steel and stainless steel, titanium and copper and its alloys. Construction techniques shall follow the requirements for hull shell, deck and internal structures. Commercially available stock components constructed of other materials as specified in this rule may be used if their use is approved in writing by the TP52 Chief Measurer.

**G.5 REQUIREMENTS****Interior.**

- G.5.1 There shall be a minimum of intrusions in the plane from the entrance hatch to the foredeck hatch up to the bunk fronts / longitudinal structure, or items crossing this plane. Specifically allowed in this plane are:

- 1) the main entrance hatch assembly
- 2) the main entrance stairs
- 3) deck beams and stringers
- 4) the equipment it takes to drive one winch positioned over (on deck) this plane by a cockpit positioned grinder
- 5) the mast (including mast related items like maststep, tierods, controllines and hydraulics related to rig functions and running more or less parallel to the mast
- 6) halyards and rig related controllines may cross this plane once (in a straight line) if grouped together in a reasonable way, so leading to one destination (like a winch, group of jammers, group of divider sheaves). Note: deck equipment like winches, jammers, etc. shall be installed on deck. See H.5.
- 7) a recess adjacent to the main entrance hatch of maximum 0.5m<sup>2</sup> to accommodate halyard winch(es), halyard/controlline jammers and other equipment required to control the lines in the recess.

Not allowed in this plane are:

Any other intrusions than permitted above, like controllines and tubes, jammers, etc. However, intrusions by controllines that to the sole final judgement of the Chief Measurer do not clash with the principle of easy and safe passage in this plane shall be seen as within this rule. As a guidance the line(s) shall not cause a crewmember having to duck lower than for normal sized deck beams or stringers.

- G.5.2 Cabin soles are only required to be fitted fore and aft from the mast bulkhead to 8.75m aft of the stem to cover any obstacle not producing a flat and clean surface, other than ring frames or other structural members. Cabin soles may be discontinuous in height and interrupted in way of ring frames or other structural members.
- G.5.3 Where a cabin sole is required it shall extend transversely to the inner skin of the hull shell or vertical faces of berth fronts, lockers or partitions.
- G.5.4 A cabin sole shall be a structure independent of the inner skin of the hull shell. It may be of any material permitted for hull, deck and internal structure provided it exhibits similar strength and stiffness characteristics to that of solid wood cabin soles.
- G.5.5 A minimum number of 8 berths is required. All berths shall be situated in such a manner that they have proper access when racing and can be angled to suit the boats heel angle up to at least 40 degrees or have a lee cloth effectively achieving the same. Berths situated on or within 0.90m of the centerline of the boat shall not be counted as part of the required number of berths.
- G.5.6 A berth shall be at least 2.0m in length measured to the inside of any structure of the berth, bulkheads or partitions encompassing the berth. The minimum width measured in a similar manner to length at the top surface of the mattress shall be 0.6m measured at 1/4 of the berth length. The foot and head ends of berths may taper as required by the hull shape.
- G.5.7 Mattresses of a size covering the entire surface shall be fitted to each berth; they shall be of a thickness not less than 0.05m. Minimum mattress density shall be 8kg/m<sup>3</sup>.

- G.5.8 The minimum height of the bottom of any berth (excluding the mattress) shall be 0.30m above the cabin sole.
- G.5.9 The minimum clearance above any mattress at the centerline over half of the length of the berth shall not be less than 0.5m.

**NOTE 1: Under this Rule it will be allowed that Regional Fleets or for this purpose TP52 Class Approved Events make different rules on the number of berths. This is restricted to reducing to a minimum number of 2 berths (fixed or pipecot).**

**HOWEVER, design of deck, cockpit, structure and equipment layout of any TP52 shall be such that without modification to these items all berths required by this rule may be retrofitted.**

**NOTE 2: From 2012 TP52's may have the minimum number of bunks required, so a minimum of 2 berths.**

- G.5.10 Galley Gear / Food / Equipment Stowage shall be provided in the form of at least 1 rigid locker, bin, or other suitable compartment with a door or lid with a positive locking device of a minimum volume of 0.20m<sup>3</sup>. Spaces below the cabin sole, or inside fixed berths, or forward of the crash bulkhead, or aft of the rudder bulkhead shall not be considered as meeting the requirements.
- G.5.11 A head shall be forward of the mast bulkhead and constructed in such a manner as to be safe for use at sea. This means it shall have sufficient handholds to secure a 100kg person in position at 30 degrees of heel. It shall be a permanently installed marine toilet operable in compliance with local regulations pertaining to Marine Sanitation Devices and their use. This toilet shall have separate proper sized (following manufacturer's instructions) seacocks for inlet and outlet.

It is recommended to have means of separation of the toilet "compartment" from the area aft of the mast bulkhead.

**NOTE: Under this Rule it will be allowed that Regional Fleets or for this purpose TP52 Class Approved Events make different rules on the type of toilet. The variation is restricted to a fitted bucket or Porta Potty type. From 2012 TP52's may use the option to have a fitted bucket or Porta Potty type toilet.**

#### **Engine and Propellor.**

- G.5.12 Each yacht must have a properly installed Yanmar inboard water-cooled diesel engine, oriented fore and aft and located on centerline, connected to a standard Yanmar sail drive with a 2-bladed folding propeller. Permitted Yanmar engine and sail drives are listed in G.5.16.

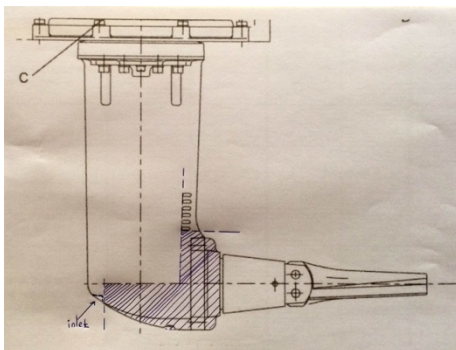

The Yanmar **engine and Yanmar saildrive** may be installed in either the “Z” or “C” configuration and **shall be otherwise installed in their complete production configuration without any modification** other than by adding filler/glass/epoxy in the “shaded” area (see drawing) and fairing the added materials into the required shape. Specifically modifying the water intakes or at any place reducing the original body of the sail drive (including the oil drain plug and standard anode) is forbidden. The complete sail drive leg may be painted to match the paint system as used for the underwaterbody or foils.

- G.5.13 The Engine Weight (EW) shall be the manufacturer's weight as mentioned in the manufacturer's manual for the engine. The minimum EW is 264kg.  
*For grandfathered engine & saildrive combinations (G.15.16) weights the minimum EW is 240kg.*
- G.5.14 The propeller installation shall not have an EDL of less than 0.600m. EDL is defined as the distance from the center of the propeller (the intersection of the blade axis and shaft) along the propeller axis to the trailing edge of the **keel**.
- G.5.15 Engine, Sail drive and fixed parts of the engine box shall be installed such that they do not reduce keel bolt access, nor do they interfere with the structure of the **keel** attachment.
- G.5.16 Permitted Yanmar Engine & Saildrive combination: 4JH57CR x SD60. If this combination is replaced other combinations will be added. Grandfathered Yanmar engine & saildrive combinations for boats launched in or before 2017: Yanmar 4JH5CE x SD60 and 4JH4-TCE x SD60.
- G.5.17 The propeller shall at all times be ready for use and shall not be retracted or shielded except by the standard strut.
- G.5.18 Propeller Type shall be folding. To qualify for measurement a "folding" propeller shall be a standard model in series production (note: under this Rule it is allowed to modify a standard model, but ONLY to reduce the PRD to suit the minimum requirements) having a minimum of two blades that fold together pivoting on an axis at right angles to the shaft line when not being used for propulsion. PRD (Propeller Diameter) shall not be less than 0.400m.
- G.5.19 Strut Drive Clearance (ST5). ST5 shall be the distance, measured perpendicular to the propeller shaft at the forward end of the strut, from the centerline of the shaft to the hull, or fair continuation of the hull. ST5 shall not be less than 0.260m.
- G.5.20 The exhaust system shall have its outlet in the stern.
- G.5.21 The engine shall be directly supplied from permanently installed fuel tankage. The tank shall be made of stainless steel and shall have a means of checking the fuel level. Alternatively, it is permitted to install an “off the shelf” rigid polyethylene fueltank chosen from a supplier's standard catalogue. Also, to include a means of checking fuel level.
- G.5.22 The minimum fuel (diesel) capacity shall be 80 liters.

**SECTION H - EQUIPMENT.****H.1 GENERAL.**

H.1.1 With equipment in this section is meant all deckgear, steering equipment, hydraulic equipment and **rigging** that is not specifically dealt with elsewhere in this rule.

H.1.2 Essentially this rule permits the use of any type of equipment mentioned in H.1.1 if complying with the **class rules** without for its use on or below deck specifically permitting each and every item as some might argue is required in a **closed class rule**.

NOTE: Any type of equipment mentioned in H.1.1 for its use above BAS in the rig or in all rigging shall either specifically be permitted by this rule or in writing by the TP52 Class Manager made available to all class members.

**H.2 CERTIFICATION.**

H.2.1 The TP52 Chief Measurer shall certify the equipment on the TP52 Certificate.

H.2.2 The equipment manufacturers / suppliers may be asked to **certify** in writing that the equipment as supplied is made in accordance with the TP52 Rule.

**H.3 MODIFICATIONS, MAINTENANCE AND REPAIR.**

H.3.1 Equipment shall not be altered in any way except as permitted by these **class rules**.

H.3.2 Routine maintenance is permitted without remeasurement and re-**certification**.

**H.4 MATERIALS AND CONSTRUCTION.**

H.4.1 Permitted Materials are: wood, natural fibres and un-reinforced plastic.

Plastic reinforced with fibre of any of the following materials: carbon with a fibre modulus maximum of 250 GPa, glass, aramid, polyester, polyamide, polyethylene and natural fibre. Iron and steel of similar or lesser properties than Nitronic 50, copper and their alloys; bronze, brass, monel, titanium and aluminum alloys of the 5000 and 6000 series.

H.4.2 Permitted materials may be anodised or coated. A colouring dye may be used as part of the anodising process.

H.4.3 Specifically:

- a) Full FRP winch drums are not permitted. The drum, in this case the part storing the line from the line entry height till where it goes for the selftailing arm or cleat, shall be made of a permitted metal/alloy.
- b) For hydraulic components and the self-tailing winches stripper arm aluminum alloys of the 7000 series are permitted.
- c) Stanchions shall be made of the materials as mentioned in H.4.1, except of aluminum alloys.
- d) Pulpits and pushpits, whether in the form of a single stanchion or a fabricated/bend shape shall be made of the materials as mentioned in H.4.1, except of aluminum alloys. (e) Lower forward/aft lifelines shall be made of 5mm 1x19 stainless steel wire.
- f) Ceramic bearings are permitted in all components provided the bearings are genuine off the shelf stock items.

**H.5 REQUIREMENTS.**

- H.5.1 Winches and their pedestals shall be placed on the deck or on cockpit pods (also read E.5.13). They shall only be operated, including tailing, from the deck or cockpit. A spinnaker retriever line winch may be placed below decks.
- H.5.2 Halyard jammers shall be placed on the deck or in the cockpit and be operational from deck or cockpit. The main halyard may have its jammer placed on the **mast** below the **mast** collar.
- H.5.3 Fastenings used shall be of the permitted materials of H.4.1.
- H.5.4 Jib and main tracks shall be placed directly on the deck or cockpit floors. They may have spacers that facilitate bridging camber, angling the tracks or to raise them with a maximum of 0.025m.
- H.5.5 Stanchion/pulpit/pushpit bases shall not be situated outboard of the edge of the working deck (see D.7.1).
- H.5.6 Pushpits, pushpit lower rails and/or stanchions shall be constructed in such a way that hiking is restricted to a maximum of 10 degrees when under a load representing the actual situation of crewmembers hiking during a race. Taken from the outboard end of the working deck to the inboard side of the lower rail for the lower rail of the pushpit and from center of the lower wire guide for the stanchions.
- H.5.7 Pushpits, stanchions and/or pulpits in any form or shape shall be constructed so that they do not flex in the direction of the lifelines under the load of any number of crew. The idea is that the top lifeline shall stay as tight as possible by being connected to solid outer anchor points.  
NOTE: Minor flex might be unavoidable, but the layout and construction of the combination of anchor and support points shall clearly show the intention to avoid flex. When in doubt, contact the Chief Measurer.
- H.5.8 All boats shall accept that a TP52 Measurer during any event with a TP52 start tensions and seals the lifelines to his judgement.

**SECTION I - RIG.****I.1 GENERAL**

- I.1.1 The sailplan shall be fractional sloop.
- I.1.2 The **mast** shall be of 3 spreader configuration.
- I.1.3 The **spars** and their fittings shall comply with the **class rules** in force at the time of certification of the spars.
- I.1.4 The **standing** and **running rigging** shall comply with the **class rules**.

**I.2 CERTIFICATION.**

- I.2.1 The TP52 Chief Measurer shall **certify** the **rig** on the TP52 Certificate.

**I.3 MODIFICATIONS, MAINTENANCE AND REPAIR.**

- I.3.1 The **rig** shall not be altered in any way except as permitted by these **class rules**.
- I.3.2 Routine maintenance is permitted without remeasurement and re-**certification**.

**I.4 MATERIALS AND CONSTRUCTION.****Mast.**

- I.4.1 The **mast**, including integral mouldings, such as tangs, spreaders and/or jumper, shall be built in section throughout its entire length substantially of carbon fibre non-sandwich reinforced plastic having a maximum fibre modulus of 452 GPa by SACMA SRM 16 / ASTM D 4018 / ISO 10618 / JIS R 7608 measured between 1000 and 6000 microstrain.
- I.4.2 Other applicable materials for **masts** and integral mouldings are: aluminum alloys of the 5000 or 6000 series, steel or stainless steel of similar or lesser strength as Nitronic 50, fiberglass reinforced plastic and glass fibre.  
NOTE: Mast sheaves may be made from titanium and have ceramic bearings
- I.4.3 The cure process shall be based on applying external heat of less than 135 degrees Celsius.
- I.4.4 Pressure applied at any time during construction shall be less than 7 Atmosphere.  
NOTE: this shall not prevent the use of construction methods using clamps, mechanical fastenings, wrapping, winding, etc.
- I.4.5 Fastenings, like screws, rivets, bolts may be used if made of steel or stainless steel.
- I.4.6 Mast builders shall provide upon request by a TP52 Measurer all relevant information on the materials and methods used to build the **rig**.
- I.4.7 The mast builder/supplier shall **certify** in writing that the **mast** and **boom** are built in accordance with the TP52 Rule, specify the highest modulus of the carbon fibre used for each item, and also specify the weight and position of any corrector weights attached to the **rig**.

**Boom.**

I.4.8 The **boom** shall be built substantially of carbon fibre reinforced plastic having a maximum fibre modulus of 395 GPa by SACMA SRM 16 / ASTM D 4018 / ISO 10618 / JIS R 7608 measured between 1000 and 6000 microstrain.

I.4.9 The **boom** may be of a sandwich construction. Any components used in the manufacture of the cores shall be of plastic foam or (Meta) Aramid Fibre paper honeycomb coated with a heat resistant phenolic resin. Specifically, the so-called Para-Aramid Fibre honeycombs based on N636 paper are not permitted under this rule.

I.4.10 Other applicable materials for **booms** are: aluminum alloys of the 5000 or 6000 series, steel or stainless steel of similar or lesser strength as Nitronic 50, fibreglass reinforced plastic and glass fibre. NOTE: boom sheaves may be made from titanium and have ceramic bearings.

I.4.11 The cure process shall be based on applying external heat of less than 135 degrees Celsius.

I.4.12 Pressure applied at any time during construction shall be less than 7 Atmosphere. NOTE: this shall not prevent the use of construction methods using clamps, mechanical fastenings, wrapping, winding, etc.

I.4.13 Fastenings, like screws, rivets, bolts may be used if made of steel or stainless steel.

**Bowsprit.**

I.4.14 The **bowsprit** shall be built substantially of carbon fibre reinforced plastic having a maximum fibre modulus of 395 GPa by SACMA SRM 16 / ASTM D 4018 / ISO 10618 / JIS R 7608 measured between 1000 and 6000 microstrain.

I.4.15 The **bowsprit** may be of a sandwich construction. Any components used in the manufacture of the cores shall be of plastic foam or (Meta) Aramid Fibre paper honeycomb coated with a heat resistant phenolic resin. Specifically, the so-called Para-Aramid Fibre honeycombs based on N636 paper are not permitted under this rule.

I.4.16 Other applicable materials for **bowsprits** are: aluminum alloys of the 5000 or 6000 series, steel or stainless steel of similar or lesser strength as Nitronic 50, titanium, fiberglass reinforced plastic and glass fibre.

I.4.17 The cure process shall be based on applying external heat of less than 105 degrees Celsius.

I.4.18 Pressure applied at any time during construction shall be less than 1 Atmosphere. NOTE: this shall not prevent the use of construction methods using clamps, mechanical fastenings, wrapping, winding, etc.

I.4.19 Commercially available stock materials like plates and tubes constructed in excess of the limits on temperature and pressure as specified in this rule may be used for small components, but their use has to be approved in writing by the TP52 Chief Measurer.

- I.4.20 Fastenings, like screws, rivets, bolts, nails, may be used if made of steel, stainless steel or titanium.

**Standing Rigging.**

- I.4.21 **Standing rigging**, except the **backstays**, the deflectors, the bobstay and the lower pendant of the **forestay** (see I.4.22), shall be Nitronic 50 or carbon of a fibre modulus not over 300 GPa by SACMA SRM 16 / ASTM D 4018 / ISO 10618 / JIS R 7608.  
All shall be nominally circular in section, except at mast, deck, spreader or bow and bowsprit intersections, where the sectional shape shall not be limited within 0.300m of an intersection point. Backstays may have 'vibration dampers' in the vicinity of the lower end fittings, these shall be no longer than 0.5 meter and no wider than 0.07 meter.  
Side rigging may have 'vibration dampers', these shall be no longer than 0.5 meter (in total if more than one is fitted) and be no wider than 0.07 meter.
- I.4.22 The construction material of the lower pendant of the **forestay**, the deflectors, the bobstay and of the **backstays** (not including the end fittings) is unrestricted, except that standing rigging shall not contain carbon of a fibre modulus over 300 GPa by SACMA SRM 16 / ASTM D 4018 / ISO 10618 / JIS R 7608.
- I.4.23 Permitted Materials for rigging fittings, like turnbuckles: Plastic reinforced with fibre any of the following materials: carbon with a fibre modulus maximum of 250 GPa, glass, aramid, polyester, polyamide, polyethylene and natural fibre. Iron and steel of similar or lesser properties than Nitronic 50, titanium, copper and their alloys; bronze, brass, monel and aluminum alloys of the 5000 and 6000 series.

**Running Rigging.**

- I.4.24 No limitations on materials for **running rigging** "ropes".
- I.4.25 Permitted Materials for **running rigging** fittings, like shackles: Plastic reinforced with fibre of any of the following materials: carbon with a fibre modulus maximum of 250 GPa, glass, aramid, polyester, polyamide, polyethylene and natural fibre. Iron and steel of similar or lesser properties than Nitronic 50, titanium, copper and their alloys; bronze, brass, monel and aluminum alloys of the 5000 and 6000 series.

**I.5 REQUIREMENTS.**

**Mast.**

- I.5.1 The **mast** shall be:
- a) Keel stepped. The maststep arrangement shall be located directly on top of the structure that is required to take the loads in this area and the height of this structure shall be lower than WLP + 0.2m. The step shall not allow the mast to rotate more than 0.5 degree when racing.
  - b) Limited in its fore - aft movement at deck level by 0.03m maximum.
  - c) Straight. Permanently bent **spars** are not permitted. A **spar** that will straighten when stresses imposed by the rigging are removed does not constitute a permanently bent **spar**.
  - (d) Structurally continuous (non-articulating) from the masthead to the step.
- I.5.2 The **mast** shall have:
- a) Straight **spreaders** of which the angle cannot be adjusted when *racing*. For the purpose of I.5.2 "straight" means that in no way hollows (or non-structural "soft spots") in the spreaders shall accommodate optimising on the roach of jibs.

The projected dimension that any spreaders leading edge can be aft of the front of the mast shall not be more than 0.045m for S1 and S2. For S3 this dimension is 0.070m.

- b) **Rigging** attached to the **mast** in such a way that their line of action passes within 0.02m of the fair surface of the mast tube.
- c) **Spreaders**, spreader roots, spreader tip fittings shall form a rigid unit and be rigidly attached to the mast except that while *racing* they may move in vertical direction (following the rigs longitudinal axis) as result of the trim of rig and sails as allowed by this rule.
- d) Three clearly discernible measurement bands of not less than 25mm at BAS, IGC and P.

NOTE: Limits as set by this rule may not be adequate from the point of structural requirements. Specific rig engineering should be completed for each individual design.

### **Boom.**

I.5.3 The **boom** shall have:

- a) A clearly discernible measurement band of not less than 25mm at E (**outer limit mark**).

NOTE: Under this Rule various **mainsails** can be used with each its own **foot lenght**. The E for each particular **mainsail** shall be indicated on the **boom** by an **outer limit mark** of a different colour and this colour shall be repeated on the **sail**, near the **clew**.

- b) A straight longitudinal top surface with a tolerance of 0.02m between the extreme ends of the **boom**.
- c) A solid boomvang fitted, which shall be ready to support the **boom** at all times.

I.5.4 A **boom** shall not have:

- a) Struts and/or outriggers.
- b) A sliding or adjustable gooseneck. The gooseneck shall be permanently fitted to the **mast** and have one position to which the **boom** is fitted. **Bowsprit and bobstay**.

I.5.5 The **bowsprit** and/or the bobstay arrangement shall not extend the effective sailing length.

I.5.6 The **bowsprit** shall be:

- a) Removable from the **hull** without damaging the structural or watertight integrity of the **hull**.
- b) Fastened to the **hull** by mechanical means only. This shall not preclude small quantities of non-structural sealing compound at the points of attachment to the **hull**.
- c) From 15 April 2014 fitted out or easily adaptable to carry two tacklines.

I.5.7 The **bowsprit** shall not:

- a) Be retractable; nor shall it pivot; nor shall it be removed when *racing*.
- b) Extend below a plane 0.200m below the freeboard at FFS. However a bobstay is permitted to go below that plane.

I.5.8 The bobstay shall attach to the **bowsprit** in the forward 20% of the bowsprit (20% of the distance most forward point **hull** - outer end **bowsprit**). And attach to / enter the **hull** not further from the waterline in measurement trim than 0.3m.

**Standing Rigging.**

I.5.9 The **rig** shall have:

- a) Discontinuous or/and continuous athwartships **standing rigging** and a single permanent **forestay** and twin **backstays** attached to the mast tube no lower than the upper limit mark. Each backstay may have one deflector line that can be controlled by block and tackle and/or hydraulic mounted on or inside the mast or a combination of both.

A (remotely operated) jammer or cleat may be used as part of the system controlling the deflector line but if mounted on or inside the mast this shall be no higher than BAS. Under tension the backstays, with the checkstays slack, shall follow a straight line over their full length.

- b) A minimum V1 shroud base and width of the lower **spreaders** measured between the centers of the cap shrouds in each case of 3.500m or more. The V1 chainplate angle shall be between 18 and 21 degrees and the chainplates of both V1 and D1 shall each have one position.
- c) Fixed **rigging** and terminals where they join in to the spreader tip fitting or if the **rigging** passes through the spreader tips it shall be fixed at that point. With the exception of:
- The rigging's terminal fitting into the spreader tip fitting may rotate allowing it to seat.
  - The center of the rotation may not move in the spreader tip fitting.
- d) The upper end of any **rigging** attached to the **mast** above a point 4.45m above the **sheerline**.
- e) **Forestay** and **shrouds** connected by conventional turnbuckles, toggles or link-plates.
- f) A luff groove device provided that such luff groove device is not made of carbon fibre, an off the shelf standard production item of constant section throughout its length and is either essentially circular in section or is free to rotate without restraint. The luff groove device shall be measured for FSP (D.19.2).  
NOTE: The **mast** may be steadied to balance a slacked off **backstay** only by use of a headsail halyard and its proper winch (or its jammer). The forestay length may be adjusted a maximum of 0.255m while *racing*.
- g) A **forestay** whose centerline intersects with the longitudinal centerline on the front face of the mast tube. No device is permitted to move the **forestay** off centerline.

I.5.10 The **rig** shall not have:

- (a) Runners and / or **checkstays** in any form. Except that one pair of backstay deflectors is permitted (see I.5.9.a). The backstays may be controlled by a single bungy that has its outer ends connected to the backstays.

I.5.11 Permitted is:

A device for measuring **forestay** tension, provided that it is incapable of adjusting the stay and has a possible movement of no more than 0.005m.

**Running Rigging.**

I.5.12 The main halyard shall be attached to the **mainsail** while sailing and the part between the headboard and the jammer shall have a minimum breaking strain of 3000kg.

I.5.13 Operating devices for securing **halyards** under tension aloft (e.g., halyard locks) are permitted only if they can be reliably released from deck level.

**SECTION J - SAILS.****J.1 GENERAL.**

J.1.1 **Sails** shall comply with the **class rules** in force at the time of **certification**.

NOTE: This includes that the RRS and WS Regulations on certification, manufacturers advertising and Class insignia, national letters and sail numbers, etc. shall be followed to the letter unless the TP52 Rule explicitly differs.

**J.2 CERTIFICATION.**

J.2.1 A TP52 Measurer shall **certify** the spinnakers at the **head**, the jibs and **mainsails** at the **tack** and shall date and sign the **certification** mark.

J.2.2 The Class Manager may approve one or more persons at a sailmaker to measure and **certify sails** produced by that manufacturer.

J.2.3 **Certification** by class approved sailmakers/measurers may be adjusted or withdrawn by TP52 Measurers.

**J.3 MODIFICATIONS, MAINTENANCE AND REPAIR.**

J.3.1 **Sails** shall not be altered in any way except as permitted by these **class rules**.

J.3.2 Routine maintenance is permitted without remeasurement and re-**certification**.  
NOTE: modifications that increase the measurements as certified shall not be considered routine maintenance.

**J.4 MATERIALS AND CONSTRUCTION.**

J.4.1 **Sail** construction shall be **soft sail**, there is no restriction on materials for the body of the **sail** if not specifically mentioned in this rule.

J.4.2 **Please note that C.7.1. requires the specifications of storm and heavy weather sails to be those of OSR 4.27.**

J.4.3 Not permitted construction details are:

- a) Artificially thickened **sails**, eg. foamed **sails** or rigid **sails**, except for protective patches at the **spreaders** or other chafing areas. Protective patches shall be one ply of fabric up to 300 grams/m<sup>2</sup> only. **Clew, tack** and **head** reinforcements shall be proportional to their function, beyond 0.6m from the **clew, tack** or **head point** a **sail** shall be flexible and capable of being folded.
- b) Multiple surface **sails**, whether inflated by the action of the wind or otherwise, except battens and batten pockets as allowed by this rule.
- c) A **sail** shall not be constructed in such a manner that any portion may be completely detached.
- d) Any device or **sail** construction which, in the opinion of the Measurer, is used to artificially alter the length or position of measurements. Such as, but not limited to, nylon braid lightly seized to the luff independent of the bolt rope. These shall be removed before measurement.

J.4.4 Permitted Materials for Mainsail Headboards and Sail Hardware are:  
Wood, natural fibres and un-reinforced plastic. Plastic reinforced with fibre of any of the following materials: carbon with a fibre modulus maximum of 250 GPa, glass, aramid, polyester, polyamide, polyethylene and natural fibre. Iron and steel of

similar or lesser properties than Nitronic 50, titanium, copper and their alloys; bronze, brass, monel and aluminum alloys of the 5000 and 6000 series.

- J.4.5 **Sail battens** shall be constructed of materials with a fibre modulus less than 250 GPa. There are no limits on the method of fabricating battens.
- J.4.6 **Sail battens** shall not be inflatable and shall be approximately straight.
- J.4.7 **Sail battens** shall be able to pass through a 0.080m diameter circle.
- J.4.8 **Sail battens** shall not be used in the **foot** of sails and have one end positioned on the **leech**.

## J.5 MAINSAIL.

### Identification.

- J.5.1 The Class Logo shall be placed in the **mainsail** (port and starboard, back-to-back only). The dimensions shall be as in Appendix 2a (1.35 x 1.37m), the colours shall be as in Appendix 2b (choice of blue, black, red, green) and it shall be placed above the 3/4 girth, preferably the center of the logo to line up with the I point.

NOTE: Events in their NOR may request to have the nation flag on the mainsail upon written approval by the TP52 Class.

### Construction.

- J.5.2 Permitted construction details are:  
Stitching, glues, tapes, bolt ropes, corner eyes, reef eyes, headboard with fixings, cunningham eye or pulley, **batten pocket** patches, **batten pocket** elastic, **batten pocket** end caps, **leech** line with pulley, **foot** line with pulley, windows, tell tales, sail shape indicator stripes.
- J.5.3 No more than 10 **battens** may be used, each on a line intersecting both luff and leech. No more than 4 of these battens may be "full length", so span **leech** to **luff**. In addition, so-called "flutter battens" may be used if no longer than 0.75m and no wider than 0.02m.
- J.5.4 Measured parallel to the line between the Head Point and the Aft Head Point at 0.5m below this line there shall be a maximum width (girth) of 2.30m.
- J.5.5 The **mid foot point**, nor any point on the **foot** shall be lower than 0.4m than the direct line between **tack point** and **clew point**.

### Area.

- J.5.5 The **mainsail** area formula:  $MSA = P/4 * (E + MQW) / 2 + (P/4 * (MQW + MHW) / 2) + (P/4 * (MHW + MTW) / 2) + (P/8 * (MTW + MUW) / 2) + (P/8 * (MUW + 1.8 \text{ or actual value up to } 2) / 2)$

**J.6 JIBS, STAYSAILS AND SPINNAKERS.**

J.6.1 Sails set forward of the mast permitted under this rule are:

- a) Jibs: trilateral sail not **set flying** (attached to the rig over at least 90% of the **luff length** by means of a luff groove device) and tacked on the centerline of the **boat**.
- b) Staysails: trilateral sail **set flying** having an LP less than or equal to 6,3m and tacked aft of the foremost point that defines J.
- c) Spinnakers: trilateral sail **set flying** of which the **half width** is 75 per cent or more of the **foot length**. Under this rule spinnakers shall be asymmetric. The **luff** shall be at least 5 percent longer than the **leech**.

NOTE: This changes RRS 50.4 where the difference between headsails and spinnakers is set at a mid-girth of 50% of the foot.

J.6.2 Bloopers are prohibited. When a spinnaker is set, no headsail or spinnaker shall be tacked in such a way as to cause or permit the **luff** or forward edge of that **sail** to lie outside of the spinnaker or spinnaker sheet.

J.6.3 Jibs, spinnakers and staysails shall be sheeted from only one point on the **sail** except in the process of reefing the **sail**. (Thus quadrilateral or similar sails or sails in which the sailcloth does not extend to the cringle at each corner are excluded.)

J.6.4 No lead for the sheeting of jibs, spinnakers and staysails shall be attached on the main **boom**.

**Jib construction.**

J.6.5 Permitted construction details are:

Stitching, glues, tapes, bolt ropes, corner eyes, reef eyes, cunningham eyes, **batten pocket** patches, **batten pocket** elastic, **batten pocket** end caps, one **leech** line with cleat, **foot** line with cleat, windows, tell tales, sail shape indicator stripes.

J.6.6 The distance, measured on the surface of the sail, between the **mid foot point** and the **half luff point** shall not exceed 55% of the **leech length**.

J.6.7 Battens may be used in jibs only if the number of **battens** is limited to 5. A maximum of two full length **battens** is permitted. PLEASE READ D.22.3.

J.6.8 The **leach** line shall be continuous and follow the "proper" **leach** of the sail between its fixing points near head and clew and not in any way accommodate the leach to locally "fold around" the spreader(s).

J.6.9 The jib area formula:

$$HSA = 0.0625 * HLU * (4 * HLP + 6 * HHW + 3 * HTW + 2 * HUW + 0.09)$$

NOTE: If the maximum offset between the edge of a headsail foot and a straight line between tack point and clew point is greater than 7.5% of HLP, then this offset shall be declared and added to HLU in the calculation of HSA as foot offset.

**Staysail construction.**

J.6.10 Permitted construction details are:

Stitching, glues, tapes, corner eyes, reef eyes, **luff** line and pulley, **batten pocket** patches, **batten pocket** elastic, **batten pocket** end caps, **leech** line with pulley, **foot** line with pulley, windows, tell tales, sail shape indicator stripes, luffrope and the required furling provisions at **head** and **tack**.

J.6.11 The distance, measured on the surface of the sail, between the **mid foot point** and the **half luff point** shall not exceed 55% of the **leech length**.

J.6.12 Battens may be used in staysails only if the number of battens is limited to 4, which must be arranged with approximately equal spacing between **head** and **clew**.

**Spinnaker construction.**

J.6.13 Permitted construction details are:

Stitching, glues, tapes, corner eyes, tell tales, sail shape indicator lines, **leach**, **luff** and **foot** lines and pulleys, lazy sheet support near tack, retriever line eyes and reinforcements.

NOTE: Under this rule only one spinnaker may have a furling device. This and permitting spi halyard locks may be modified in an event or series NOR. Spinnakers shall not have battens.

**Spinnaker area.**

J.6.14 The spinnaker area formula:

Spinnaker Area = SPA =  $((SLU + SLE)/2) * (SFL + (4 * SHW))/5) * 0.83$

NOTE: SLU is **luff length** of the asymmetric spinnaker, SLE is **leech length** of the asymmetric spinnaker, SFL is the **foot length** of the asymmetric spinnaker and SHW is the **half width** of the asymmetric spinnaker.

**J.7 MEASUREMENT.**

J.7.1 All **sails** shall be measured and certified.

J.7.2 A Measurer shall **certify** the spinnakers at the **head**, the jibs and **mainsails** at the **tack** with a sticker showing the actual measurements found, his or her WS In-House Serial Number, signature and date of measurement.

J.7.3 The dimensions to be recorded are:

**Mainsails:** MHB, MUW, MTW, MHW, MQW, E (as intended for this sail), MSA (see J.5.5) Jibs: HLP, HLU, HHW, HTW, HUW, HSA and if required foot offset (see J.6.8) Spinnakers: SLU, SLE, SHW, SFL and SPA (see J.6.13)

J.7.4 If the **sail** or the measured data do not comply with the appropriate definitions and restrictions as set forth in this rule its Measurer is strongly advised to inform his client. The **certification** solely indicates the actual dimensions of J.7.3. as recorded at the time of measurement, not that the sail is compliant with this rule. A TP52 Class Measurer may be asked for advice at all times.

**Section K - MEASUREMENTS.****K.1 GENERAL.**

- K.1.1 It is the principle of measurement under the TP52 Rule that all measurements are taken either by hand with measurement tape, or in case of weights by certified scales or loadcells as approved for use by the TP52 Chief Measurer. However to the discretion of the TP52 Class Annual Meeting the Members may decide to keep in place determination of the boat's RM in order to facilitate an efficient check during events on uncertified changes of the boats ballast or equipment.
- K.1.2 The Metric System shall be used for measurements under the TP52 Rule. Length measurements shall be measured in meters to three decimal places on the **hull and rig. Sails** shall be measurements to two decimals places. Weight shall be in kilograms. **Crew** weights shall be to one decimal place. All other weights to a kilo, unless specified different in the TP52 Rule or TP52 Interpretations.
- K.1.3 Only TP52 Measurers appointed by the TP52 Chief Measurer, in consultation with the TP52 Class Manager, and/or with the approval of the TP52 Executive Committee shall measure a **boat** for a TP52 **Certificate**. The Measurer shall maintain records of all notes, sketches and worksheets used in preparing the measurement input.
- K.1.4 Modifications normally require remeasurement. In case there is no evidence of changes a TP52 shall not be remeasured and processed except where the TP52 Chief Measurer or Class Manager is satisfied that reasonable evidence of error exists.
- Where it is determined that there is sufficient evidence to undertake remeasurement to validate a **boat's** certificate values, the following procedures shall be observed:
- a) **boat** shall be set up in trim identical to that for the current measurement except where trim itself is deemed not to comply with measurement procedures, in which case trim shall be corrected.
  - b) Two measurers shall work together and the TP52 **Certificate** produced on the basis of the new measurements shall replace the previous **certificate**.
- K.1.5 To secure an accurate and fair measurement, it is necessary to have close co-operation between Owner and Measurer. It is desirable, therefore, that the Owner be reasonably familiar with the requirements below.

**K.2 ASHORE**

- K.2.1 The **hull and hull appendage** measurements and propeller installation measurements shall be taken ashore with the **boat** exactly level athwartships and approximately in the same longitudinal trim which it might reasonably be expected to assume when afloat in measurement trim.
- K.2.2 The **boat** shall be presented for measurement ashore in an accessible location, clear of obstructions, properly and firmly chocked and leveled as above. The **boat** shall rest in its build or transport cradle and the **keel** shall be at least 0.15m of the floor and unsupported. **Rigging** shall be slack. All **hull appendages** shall be fitted and any rudder fairings shall be in place. Cradle support struts and athwartships cradle bulkheads can usually be accommodated but supports prohibiting making required measurements shall be avoided.

- K.2.3 Fin and bulb, as well as bulb ballast, fastenings, washers, spacer plates, shall be presented separately for measurement. There after the **keel** (fin and bulb assembled) shall be presented for measurement, before being fitted to the hull for the measurement of the complete boat.
- K.2.4 The weight of the lead in the ballast cavity as required by this rule shall be noted on the TP52 **Certificate**.

### **K.3 AFLOAT**

- K.3.1 Freeboards and Trim Points shall be measured on one occasion with the **boat** afloat in measurement condition/trim (see K.3.4 below). A dinghy or raft must be available for use by the Measurer. The Owner or the Owner's Authorised Representative (see Measurement Inventory Form, Appendix 3) must be present for flotation measurement.
- K.3.2 Specific Gravity (SG): The specific gravity of the water shall be measured at this time and recorded as SG. The water shall be sampled from a level 0.3m below the surface.
- K.3.3 The Owner or his representative will put the **boat** in measurement condition/trim by following the procedure defined below. The Measurement Inventory set out in Appendix 3 shall be used to ensure and record compliance with the requirements. No substitutions are permitted during measurement afloat.
- K.3.4 The **boat** shall be completed and equipped for sailing. The following items shall not be on board for weighing and taking freeboards and trimpoints:
- a) Sails, jib and spinnaker sheets, spare **standing** and **running rigging**.
  - b) Fuel, water and the contents of any other tanks, except hydraulic tanks.  
Hydraulic systems including hydraulic tanks shall be full for measurement and shall remain full when racing.
  - c) Gas bottles.
  - d) Food, cooking and catering utensils.
  - e) Mooring lines and fenders.
  - f) Clothing, bedding and personal effects.
  - g) All removable safety equipment excluding anchors, chains and warps.
  - h) Tools and spare parts.
  - i) Loose gear.
  - j) **Crew**.

Further:

- a) All **standing rigging** and related fittings used whilst *racing* will be attached in their normal positions. All **halyards** and lifts shall be taken to the **foot** of the **mast** and hauled tight. All **halyard** tails shall be taken to their normal working positions.
- b) The **boom** shall be secured on the centreline in horizontal position. The **Mast** shall be raked aft to the limit of its adjustment. Where this limit is forward of the vertical the **mast** shall be set vertical.
- c) The **boat's** head shall not be depressed through lying to a mooring.
- d) Ballast shall be fixed below the cabin sole, or as low as possible at any station and sealed to the **hull** structure to prevent movement.
- e) Anchor, chain and warp shall be secured in clearly marked stowage positions aft of the mast. **Boats** shall be measured with one anchors (see C.5.3). (The anchor shall remain properly secured at their stowage positions whilst racing, unless

their intended use is required).

- f) The batteries shall be secured in their proper stowage. The weights of ballast, anchors, chain and warps and batteries and their distances from the stem will be recorded on the Measurement Inventory. (Where the height of the stowage is unusual it shall be noted.)
- g) All tanks shall be empty at the time of measurement, except where the Measurer has authorized otherwise.
- h) Bilges and other areas where water may collect shall be dry. There must be no effort to artificially moisten decks, **rig**, equipment or gear.

NOTE: When for practical reasons it is not possible to remove all items and equipment (e.g. fuel), it is acceptable to deduct the weight of these from the measured weight.

The rating authority reserves the right to refuse such data when inadequate detail is supplied.

- K.3.5 The vertical height above the waterplane of the port and starboard, fore and aft freeboards shall be separately measured to the Freeboard Points (see D.8.1) recorded and permanently marked at the time of hull measurement ashore.
  - a) Freeboard Forward Measured (FFM) shall be recorded as the average of the respective port and starboard freeboards forward.
  - b) Freeboard Mast Measured (FMM) shall be recorded as the average of the respective port and starboard freeboards at the mast.
  - c) Freeboard Draft Measured (FDM) shall be recorded as the average of the respective port and starboard freeboards at the deepest point of the **keel**.
  - d) Freeboard Aft Measured (FAM) shall be recorded as the average of the respective port and starboard freeboards aft.

K.3.6 *LENGTH ON WATERPLANE (LWP) is to be shown on the Certificate for the purpose of facilitating an endorsed IRC Rating based on the TP52 Certificate. The measurement points are shown on the diagrams for hull shapes and are defined in Appendix ... LWP is calculated by the subtraction of bow (BO) and stern (SO) overhangs from length overall (LOA). The dimension 'y' shall also be supplied and dimensions 'h' and 'x' if appropriate. All measurements shall be taken with the boat in the measurement condition (see Rule K.3.4).*

#### K.4 SAILS AND RIG

- K.4.1 All **sails, spars** and **standing rigging**, adjustable or fixed, must be available to the Measurer for measuring or checking marked dimensions and declarations made as to the use of these while *racing*.
- K.4.2 Measurements may be taken to locations defined by painted bands, of white or other contrasting colour, only when these bands are in place at the time of measurement. Where measurements are taken to such bands, movement of the bands or a failure to display them whilst *racing* shall invalidate the TP52 **Certificate**.
- K.4.3 Assessment of Rig Limits compliance requires measurement and weighing of the rig. A rig shall be measured for total rig weight (MWT) and vertical center of gravity (MCG), prepared as specified under D.12.4. For limits see D.12.
- K.4.4 Measurements shall be taken parallel to the axis of the **spar** with the **spar** straight. Excluding a luff groove device, no hollows in the section are permitted. Any addition of material to the base **mast** section shall consist of the same primary structural material as the **mast** itself. The MDL1 measurement shall include any bona fide luff

groove or track attached directly to or integral with the **mast**. Any secondary luff groove device otherwise attached shall not be included and the relevant **boom** and **mainsail** measurements shall be increased by the longitudinal dimensions of the device as determined by the Measurer.

- K.4.5 The height of deck used as a datum for **sail** area measurements shall be the **sheer line** abreast the front of the **mast**.
- K.4.6 A TP52 shall only be measured with the rig in measurement trim, which is with the **lower limit mark** (BAS) in the position as recorded on the TP52 **Certificate**, the heel on the step halfway its most fwd and most aft position (class rule C.6.1 (b)), the step base plate positioned as during racing, the headstay fitted with strop/link(s) as (most) used when racing and headstay ram halfway between fully in and fully out. Tension on backstays just enough to take slack out of headstay and boom horizontal.
- K.4.7 The Rigplan and **Mast** are to be checked and confirmed by the Measurer to be according the TP52 Rules and recorded on the TP52 **Certificate** as follows:
- a) Rigplan and **Mast**: Pass
  - b) Stroke, forestay adjustment shall be recorded and not be longer than 0.255m:  
Pass
  - c). Rigging: Pass
  - d) Halyard locks meet rule: Pass
  - e) Corrector weights may be added to the **mast** or **spreaders**. They shall be declared and their weight and position noted on the **certificate**.
  - f) Shims: number/thickness. Total height:...mm.
  - g) Backstays: pass
  - h) No runners / checkstays: pass
  - i) Halyard sizes at time of weighing the boat: ..... j) IGC band in place: pass
  - k) E measurement(s): .....
  - l) Mastbuilder Declaration: pass
  - m) Sails: pass

**SECTION L - OWNER'S RESPONSIBILITIES.****L.1 GENERAL**

L.1.1 Before a TP52 **Certificate** is valid it must be signed by the Owner of the **boat**. The name of the individual who signs the TP52 **Certificate** shall also be printed on the **Certificate**. By this signature the Owner signifies that he or she understands the Owner's responsibilities under all parts of the TP52 Rule, a copy of which shall be aboard while *racing*.

L.1.2 The Owner shall have the primary responsibility for ensuring compliance with the TP52 Rules. When the person in charge of the **boat** while *racing* is not the Owner, he shall be equally responsible for compliance.

L.1.3 Owner's responsibilities are divided into three categories: • Owner's responsibilities prior to and during measurement.  
• Owner's responsibilities after measurement.  
• Owner's responsibilities whilst racing.

**Prior to and during measurement.**

L.1.4 The Owner is responsible for arranging measurement with the TP52 Measurers.

L.1.5 The Owner shall present the TP52 for measurement ashore in an accessible location, clear of obstructions, properly chocked and leveled. The **keel fin** and **bulb** shall be presented for measurement separately as well as joined together, before they are fitted to the **hull** for the measurement of the **boat**. Adequate lifting equipment shall be provided by the Owner.

L.1.6 This Rule requires each new **boat** to be fully measured, in other words using data of **boats** from the same mould or plug will not be allowed.

L.1.7 The Owner shall on another occasion make the **boat** available at a suitable location agreed with the Measurer so that flotation measurements may be taken.

L.1.8 The Owner is responsible for preparing the **boat** in **measurement trim** as specified in K.3.4. He shall declare to the Measurer the weight and location of all ballast. He shall, together with the Measurer, complete and initial the Measurement Inventory and Check List (See Appendix 3).

L.1.9 The Owner is responsible for declaring to the Measurer all **spars** and **sails** that he proposes to carry on the **boat** and the location in which he proposes to set them, so that they may be properly measured.

L.1.10 The Owner is responsible for declaring to the measurer the type of **hull** construction, the type of **hull appendages** construction and materials of which the **hull**, **hull appendages** and **spars** are built.

**After Measurement.**

L.1.11 It is the Owner's responsibility to declare to the TP52 Chief Measurer any changes made to the **boat**, its **rig**, or its equipment which could change any of its measurements under the rule. Such changes could be:  
a) Changes of ballast in amount or location or configuration.  
b) Change of tankage, fixed or portable, in size or location.

- c) Any changes in the engine and/or propeller installation.
- d) Addition, removal or change of location of gear or equipment, or structural alteration to the **hull**, that affect the trim, VCG or flotation of the **boat**.
- e) Movement of any measurement bands used in **sail** area measurement, or any changes in **spars, spar** location or **forestay** position.
- f) The Owner shall be responsible for ensuring that all **mainsails**, jibs, staysails and spinnakers bear the official TP52 Sail Stamp and are marked by the Measurer as required under J.2.1.  
He shall also be responsible for ensuring that the **sails** and these marked dimensions do not contravene the values stated or permitted for them on the TP52 **Certificate**.
- g) Changes to **spars** or **standing rigging** configuration, including elements of **rigging** identified as adjustable while *racing*.
- h) Changes to the Elements influencing the DSPM (Displacement), including hull, deck and appendage construction, **spars**, accommodation and rig configuration, etc.

**Pre-Season Check.**

- L.1.12 It is the intention to measure or check all TP52's that race in the same geographical area (like the Western Med) and that plan to be active in the same competition (like the 52 Super Series) at the start of the season with the same equipment and by the same team during a fixed period (like one week) in the same location (like a port or town).  
If such an arrangement is made and announced at least 60 days prior to the actual dates of measuring not participating in this arrangement, to the discretion of the Chief Measurer, may be reason to refuse the TP52 Certificate, or to impose additional requirements for obtaining the TP52 Certificate.

**While Racing.**

- L.1.13 The Owner is responsible for ensuring that the TP52 Rule, Bylaws and Interpretations are aboard the **boat** and that all members of the **crew** fully understand and comply with the limitations which apply whilst *racing*.
- L.1.14 **Sails** shall only be set in those areas declared for measurement, and no **sail** shall be carried on board which does not comply with the definitions and restrictions for such a **sail** as set forth in this rule.
- L.1.15 The Owner is responsible for ensuring that when the engine is run for any purpose the propeller does not rotate.
- L.1.16 Shipping, Unshipping or Shifting of Ballast, Fixtures and Accommodation:
- a) The removal for racing of fixtures and items of accommodation which were aboard for in water measurement is not permitted.
  - b) Attention is called to Section 51 of the RRS - Moving Ballast: "All movable ballast shall be properly stowed, and water, dead weight or ballast shall not be moved for the purpose of changing trim or stability. Floorboards, bulkheads, doors, stairs and water tanks shall be left in place and all cabin fixtures kept on board".
  - c) Note that unwarranted quantities of stores shall be considered as ballast under this rule. Any liquid carried on board in excess of 2.5 liters of drinkable fluid per person per day of *racing*, in the tanks or in other containers is not permitted. Race Organizers may waive this requirement by so specifying in the Notice of Race or Sailing Instructions.

- L.1.17 One fuel tank shall be operable and carry not less than 25 liters of fuel. Race Organizers may waive this requirement by so specifying in the Notice of Race. But the fuel tank shall not carry more than 50 liters when *racing*.
- L.1.18 Portable equipment, gear, **sails** and stores may only be moved from stowage for use in their primary purpose. Stowage in this respect is the position for any item of equipment or stores, to be maintained for the duration of a race or series, when such item is not in use for its primary purpose.  
NOTE: Moving sails or equipment with the intention of improving performance is prohibited and shall be considered a contravention of RRS 51.
- L.1.19 Other than bilge pumps and hatch seal pumps, no device, unless permitted under RRS 52 Manual Power, shall be used whilst *racing* which derives assistance from energy stored to do work. Specifically, the power to adjust and / or operate standing rigging, running rigging, spars (these three cover the adjustment and operation of the sails) and rudder shall be manual power (the force exerted by crew) or the effect of direct contact with wind and/or water.  
Except for:  
a) small springs, shockcord and similar devices.  
b) air return systems in hydraulic rams.  
c) low pressure hydraulic reservoirs of less than 6 bar which provide back pressure to a hydraulic system to prevent cavitation, but do no significant work themselves.  
It is explicitly forbidden to operate hydraulic valves, hydraulic systems and / or winch systems in any other way than manually (the force exerted by crew, so by any body part: hand, foot, etc.).
- L.1.20 Unless this rule is specifically exempted in the Sailing Instructions the Owner shall be responsible for ensuring that the weight of the **crew**, weighed in sailing shorts and T-shirt as used by the **crew** when *racing*, on board the **boat** for any race does not exceed the Maximum Crew Weight. See TP52 Rule C.2.

**INDEX OF SYMBOLS**

AF	J.6.13
ALE	J.6.13
ALU	J.6.13
AMG	J.6.13
ASA	D.32
BAS	D.28
BD	D.29
BHM	D.11.1
BTP	D.8.3
BV	D.11.1
BWT	D.12
CPW	D.33
D	D.10
DSPM	D.9
E	D.26
EDL	G.5.20
EW	G.5.19
FA	D.8
FAM	D.8.2
FD	D.8
FDM	D.8.2
FF	D.8
FFM	D.8.2
FM	D.8
FMM	D.8.2
FSP	D.19.1
HB	D.3
HHB	D.20
HL	D.2
HSA	D.31
I	.16
IGC	D.17
ISP	D.23
J	D.18
JGM	D.22
JGU	D.22
KWT	D.11.1
LL	J.6.8
LP	D.19
LPG	D.19
MCG	D.13
MDL	D.14
MDT	D.15
MGL	J.5.5
MGM	J.5.5
MGU	J.5.5
MGT	J.5.5
MHB	D.27
MSA	D.30
MWT	D.12
P	D.25
PRD	G.5.24
ST5	G.5.25
STL	D.24
STP	D.8.3

APPENDIX 1

TP52 Certificate



2026 TP52 Certificate

<b>Boat Name:</b>	<b>Owner:</b>
<b>Certificate No:</b>	<b>Rep:</b>
<b>Issue Date:</b>	<b>Address:</b>
<b>Valid until:</b>	
<b>Sail Number:</b>	<b>Team Email:</b>
<b>Designer:</b>	
<b>Builder:</b>	<b>ISAF Plaque No:</b>
<b>Issued by Chief Measurer:</b>	<b>TP52 Class Manager:</b>
	Rob Weiland

**Boat Weight:**

<b>Owner:</b>				<b>Date:</b>	
<b>Representative:</b>				<b>Date:</b>	
<small>I have read and understand the TP52 Rules and will conform to them while racing.</small>					
<b>Rule Elements:</b>					
Hull	pass	TP52	pass	Measurer	Pablo Ferrer
Deck	pass	Engine	pass		
Foils	pass	Sails	pass		
GI Declaration:	pass	Builder Declaration:	pass	Mastbuilder Declaration:	pass
				Equipment Declaration:	pass
<b>Comments:</b>					

Yacht Name:



TP52 Certificate: page 2

Certificate No:

Issue Date:

Hull & Fella	Rule	Description	Min	Max	Value	In Box
HL	D.2	Length Overall	-	15.858		pass
HB	D.3	Maximum Beam	4.300	4.420		pass
DSPM	D.9	Leadball Weight	8975			pass
D	D.18	Keel Draft measurement side (DTS - FMD)		3.500		pass
FF	D.8.1	Forward Freeboard Location	0.430	0.470		pass
MF	D.8.1	Mast Freeboard Location				
DF	D.8.1	Draft Freeboard Location				
AF	D.8.1	Aft Freeboard Location	14.350	14.300		pass
FF	D.8.2	Forward Freeboard Height	1.460			pass
MF	D.8.2	Mast Freeboard Height	1.260	-		pass
DF	D.8.2	Draft Freeboard Height		-		
FA	D.8.2	Aft Freeboard Height	1.140			pass
<b>Propulsion</b>						
EW	G.5.18	Engine Weight	384 (3018)	-		pass
EDL/PGU/STB	G.6.20/24/26	Prop Installation	0.60.4/0.26	-		pass
<b>Spars</b>						
F	D.25	Mainmast Height		20.400		pass
E	D.26	Beam Length	7.000			pass
BAS	D.28	Beam Above Sheerline	2.100	2.130		pass
BD	D.29	Beam Depth		0.380		pass
ISP	D.23	Spinnaker Mast Height		22.400		pass
I	D.14	Foretriangle Height		19.720		pass
J	D.18	Foretriangle Base		8.200		pass
STL	D.24	Bowsprit Length		9.000		pass
CPW	D.23	V1 Chain Plate Width	3.500			pass
Stroke	C.4.2.3	Headstay Stroke		0.295		pass
<b>Mast</b>						
MWT	D.12	Mast Weight	235.0			pass
MCG	D.13	Mast VCG Above Sheer	9.350			pass
MDL	D.14	Mast Longitudinal	0.280	0.340		pass
MOT	D.15	Mast Transverse	0.130			pass
BWT	D.12	Beam Weight	30.0			check
<b>Jibs</b>						
LP	D.19	LP - Jib		6.300		pass
XQU / XQM	D.22	Girth Measurements		1.8 / 3.25		pass
FSP	D.19	2x Luff Support Device		0.080		pass
HSA	D.21	Headstay Area		86.000		pass
<b>Spinnakers</b>						
ASA	D.22	Spinnaker Area		270.0		pass
<b>Mainmast</b>						
	Max	M 1	M 2			pass
MHG	3.000					pass
0.5m With	3.000					pass
Area	86.00					pass
	Min					
E	TD00					pass
<b>TP52 Boat</b>						
<b>Elements &amp; Stepside</b>	Ballast Tronks / Position:	from J			Accommodation requirements	pass
	Boat speed under power	pass			Engine & Saildrive	pass
	Hull and deck shape	pass			Pushpit/Pulpita/Steerchairs	pass
	Full Configuration	pass			Equipment Materials	pass
	Keel limits	pass			STP -	
	KW (4800) and RW (2800)				STP -	
<b>TP52 Rig &amp; Sail Elements</b>						
Sailplan & Mast	pass				Mast Stows number/height:	nom
Boom Connector Weight max. 1kg	pass				E-measurements as:	
Backstay / Checkstay	pass				E1 Position m Colour:	
Mast Connector Weights	pass				E2 Position m Colour:	
IGC band in place	pass				Halyard locks meet rule	pass
Movement mast at deck end stop	pass				Jib Head 0.15max	pass

APPENDIX 2a

CLASS ASSOCIATION MARKINGS

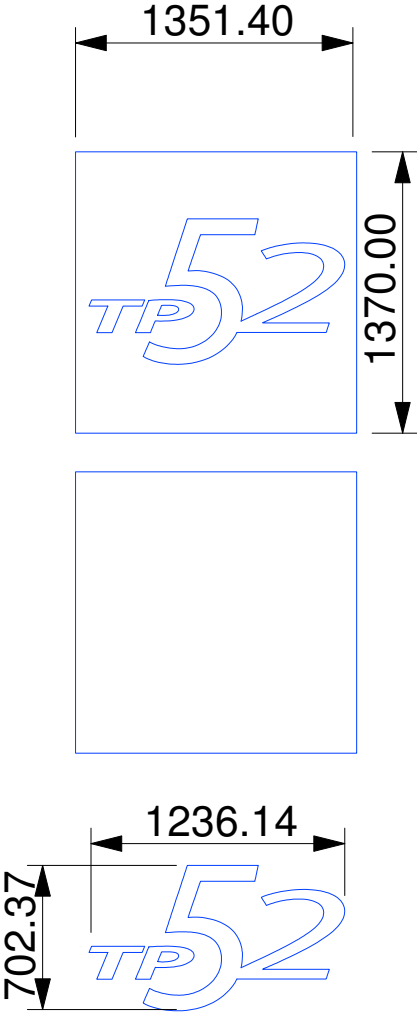

APPENDIX 2b

CLASS ASSOCIATION MARKINGS



**APPENDIX 3****MEASUREMENT CONDITION CHECK LIST & INVENTORY**

This check list is intended to help the Owner prepare the **boat** for measurement. The **boat** shall be completed and equipped for sailing.

All loose gear and equipment shall be removed, like:

- a) Sails, jib and spinnaker sheets, spare **standing** and **running rigging**.
- b) Fuel, water and the contents of any other tanks, except hydraulic tanks. Hydraulic systems including hydraulic tanks shall be full for measurement and shall remain full when racing.
- c) Gas bottles.
- d) Food, cooking and catering utensils.
- e) Mooring lines and fenders.
- f) Clothing, bedding and personal effects. (One mattress for each bunk to remain in situ).
- g) All removable safety equipment, excluding anchors, chains and warps.
- h) Tools and spare parts.
- i) Loose gear.
- j) **Crew**.

**NOTE:**

- 1) Ballast shall be sealed to the hull structure and the anchor with chain/rope (25kg) as well as the batteries shall be fixed in clearly marked stowage.
- 2) Heads, bowls, sinks, etc. are dry.
- 3) Bilges and other possible areas where water may collect are dry.
- 4) Tankage (empty) and voids condition (dry) to be checked.
- 5) Check no loose gear, clothing, bedding or equipment is left on board.
- 6) All stowages opened and checked.
- 7) No liferaft and/or dinghy on board.
- 8) All standing rigging tight, BAS as on TP52 Certificate.
- 9) Mast positioned at deck and step as described in TP52 Rule.
- 10) Running rigging in normal position and tight. Halyards led to the foot of the mast.
- 11) Backstay tight, forestay fully extended.
- 12) Hydraulic systems, including tanks, full for measurement and to remain full racing.
- 13) Boom horizontal, centred and secured against movement.

**APPENDIX 4****RULES AND PROCEDURES FOR RACE ADMINISTRATION**

The following shall apply to races conducted under the TP52 Rule:

1) Pre-race Inspection or Measurement.

When, as a result of any pre-race inspection or measurement, it is determined that a **boat** does not conform to its TP52 Certificate:

- a) When the non-conformance is considered to be minor and can be easily corrected, the **boat** may be brought into conformance with her **certificate**, or, when necessary, a new **certificate** may be issued. The measurer appointed for the series shall report all such corrections to the protest committee.
- b) When the protest committee considers that the non-conformance is major (even if it can be corrected) or that it cannot be corrected without requiring significant remeasurement, they shall act in accordance with RRS.

2) During a Race or Series.

When, as result of an inspection, **measurement**, or protest during a race or series, it is determined that a **boat** does not conform to its **certificate**, the facts shall be referred to the protest committee which shall act in accordance with the RRS:

- a) When the non-conformance is considered to be minor (whether or not the **boat** is issued with a new **certificate**), the original **certificate** shall be considered valid throughout the race or series.
- b) When the non-conformance is not considered to be minor the **boat** shall receive a 50% place penalty in any race in which her measurement was incorrect.
- c) When a **boat's** TP52 Certificate is withdrawn by the TP52 Chief Measurer under the provisions of the TP52 Rule, the matter shall be referred to the protest committee which shall act in accordance with the RRS and may disqualify the **boat** from all races in the series or take such other action as it deems proper.
- d) The results of a race or series shall not be affected by measurement protests lodged after the prizegiving or such other time as the Sailing Instructions shall prescribe. Nothing in this paragraph shall bar action under the RRS concerning a **boat** deliberately altered.

3) General:

- a) When a **boat** is checked at an event or as a result of a protest, the measurement shall be checked using the rule as is in effect at the time of the protest.
- b) The TP52 Chief Measurer or the TP52 Measurer in whose waters the **boat** is racing would normally be the "authority qualified" referred to in the RRS to resolve questions involving TP52 **Certificates**. A protest committee considering a protest involving a TP52 **Certificate** may submit questions to them to which they shall provide all reasonable advice and assistance to resolve the protest. The measurements resulting from a protest remeasurement shall be used to issue any new **Certificate**.

4) Investigation and Reporting of Rating Irregularities:

- a) When, as a result of an action in a race or series or the withdrawal of a TP52 **Certificate** by the TP52 Chief Measurer, a **boat** is remeasured and found not to comply with the TP52 Rule or Interpretations, the TP52 Chief Measurer shall further investigate the circumstances and report its findings to the TP52 ExCom which may take such further action as it deems proper.
- b) Race and protest committees are asked to report all actions arising under 1(b), 2(b)

and 2(c) above to the TP52 Chief Measurer. Such reports may be made through the TP52 Measurer of the area of organizing authority's event.

5) Other Actions.

This Appendix only concerns actions with respect to boats. It does not limit in any way the rights and responsibilities of race and protest committees and of National Authorities to investigate or act with respect to individuals.

**APPENDIX 5****ADMINISTRATIVE MEASUREMENT PROTESTS**

1. The TP52 Chief Measurer or the TP52 Measurer in whose waters the boat is lying would normally be the "authority qualified" referred to in the WS Rules to resolve questions involving TP52 **Certificates**. A protest committee considering a protest involving a TP52 **Certificate** may submit questions to them to which they shall provide all reasonable advice and assistance to resolve the protest.
2. Administrative Protests.
  - a) The administrative protest procedure permits protests involving a **boat's certificate** without regard to whether the **boat** was *racing*. An administrative protest shall be lodged with the TP52 Chief Measurer.
  - b) Any person or organisation which has a valid interest in a **boat's** certificate may lodge an administrative protest, provided that:
    - The protest is in writing and is signed and dated by the protestor;
    - The protest includes a detailed description of the alleged defects and a full statement identifying the protestor as having a valid interest;
    - The protest is accompanied by a copy of the **certificate** of the **boat** being protested;
    - The protest includes a statement of the issues the protestor wishes to have resolved, identification of the applicable rules and any relevant evidence.
  - c) The Owner of the protested **boat** shall file a reply with the TP52 Chief Measurer as soon as possible. If he elects to concede the protest or refuses to cooperate in providing for remeasurement when required, the TP52 Chief Measurer shall invalidate the **boat's certificate** and so advise all concerned.
  - d) The TP52 Chief Measurer shall consult the TP52 Class Manager (Bylaw 4.2.11), he may consult TP52 Measurers, external experts and/or the TP52 ExCom. He shall make his decision based on the available evidence and may order remeasurement of the boat in whole or in part.
  - e) The decision of the TP52 Chief Measurer shall determine any measurement and processing costs of deciding the protest and determine which party will pay, as follows:
    - When the correct data of the protested **boat** do not differ from the data on the contested TP52 **Certificate**, or to the opinion of the TP52 Chief Measurer the difference is down to measurement inaccuracies or external reasons (like for instance temperature conditions), the protestor will be responsible for the measurement and processing costs. The filing fee will not be counted toward payment of costs.
    - When the correct data of the protested **boat** differ from the data on the contested TP52 **Certificate** for reasons that to the opinion of the TP52 Chief Measurer are a result of other reasons than described in Part 9 - Owners Responsibilities -, the TP52 Class will be responsible for the measurement and processing costs. The filing fee will not be counted toward payment of costs.
    - When the correct data of the protested **boat** differ from the data on the contested TP52 Certificate for reasons that to the opinion of the TP52 Chief Measurer are a result of neglect of the duties as described in Section L - Owners Responsibilities -, the measurement and processing costs will be borne (or shared) by the owner (with the TP52 Class) depending upon the determination of responsibility for the difference. The filing fee will be returned to the protestor.

3. Appeal of Rule Interpretations by the TP52 Class Manager.
  - a) When an Owner believes that a Rule Interpretation is not correct, he/she may appeal the Interpretation with the TP52 ExCom, stating the relevant facts.
  - b) The TP52 ExCom shall appoint a committee from its members to investigate, hear, and decide on the request following WS Regulation. It shall ask the advice of a Technical Committee (Bylaw 4.2.10) and WS (if not represented in the Technical Committee).

#### RULE INTERPRETATIONS

1. The TP52 Class Manager is in charge of Rule Interpretations (Bylaw 4.2.9).  
The TP52 Class Manager or the TP52 Measurer in whose waters the boat is lying would normally be the "authority qualified" referred to in the WS Rules to resolve questions involving the TP52 Rules. A protest committee considering a protest involving a TP52 Rule may submit questions to them to which they shall provide all reasonable advice and assistance to resolve the protest.
2. Appeal of Rule Interpretations by the TP52 Class Manager.
  - a) When an Owner believes that a Rule Interpretation is not correct he/she may appeal the Interpretation with the TP52 ExCom, stating the relevant facts.
  - b) The TP52 ExCom shall appoint a committee from its members to investigate, hear, and decide on the request following the procedures of the WS Racing Rules.  
It shall ask the advice of a Technical Committee (Bylaw 4.2.10) and WS (if not represented in the Technical Committee). In the event that there is reasonable doubt about the interpretation the TP52 ExCom may withdraw or reword the Interpretation. In case the decision goes against the expert advice this shall be explained in the decision.